



WATER SUPPLY IN EMERGENCIES

Introduction

In the immediate aftermath of a disaster, displaced populations in emergency shelters will require a safe and sufficient water supply. In some circumstances there may be no existing supplies locally, and water will have to be brought in from other sources. Alternatively, there may be local sources that need protecting to ensure they don't become contaminated.

The provision of water in an emergency requires quick and simple solutions, and the extent to which a People-Centred approach can be followed is limited by the immediate need for water access. The concept of People-Centred Reconstruction (PCR) requires time to develop responsibilities and skills amongst displaced communities; primary concerns should be focussed on the provision of safe water, but methods can be adopted to encourage participation in the assessment and securing of water sources. Practical Action's [Practitioner Tools on PCR](#) offer advice on how to integrate communities into processes.

The Water, Engineering and Development Centre (WEDC) at Loughborough University has produced a comprehensive manual on the assessment of [Emergency Water Sources](#), available for free download. Additionally, the United Nations High Commissioner for Refugees (UNHCR) has produced a [Field Guide for Water and Sanitation in Emergencies](#) and an [Emergency Handbook](#). This technical brief draws on these external sources, and is intended as a summary of the key stages in emergency water supply, and gives an overview of some of the appropriate solutions to improve the process that are compatible with a PCR approach.

Immediate Actions

There are key actions that it may be necessary to undertake in the immediate aftermath of a disaster, with regards to securing a safe water supply for the displaced population (Davis, J. and Lambert, R. 2002):

- Assess existing sources & identify new sources
- Organise tankering
- Protect sources
- Provide distribution, transport & storage
- Provide treatment
- Promote hygiene
- Monitor and evaluate

Practical Answers has a web-page with links to WEDC and WHO technical sheets on several aspects of emergency action [here](#). It may not be necessary to undertake all of the actions, depending on the results of the preliminary assessment.

▪ Assess existing sources & identify new sources

To plan how best to supply water to a displaced population, an initial assessment is required to understand the following:

- Requirements of displaced population
- Condition of any existing water supplies
- Priorities of whom?
- How to plan for long-term solutions

By making sure the requirements are well understood from an early stage, valuable time can be saved later on. The Practical Action publication: 'Engineering in Emergencies' ([available here](#)) details a basic questionnaire for water supply assessment, whilst a more detailed list is supplied by the WEDC manual. A summary of the main considerations is below:

1. How many people are affected, and where are they?
2. Are any diseases present, or are they likely to appear?
3. Is there currently sufficient water, how long will it last and are there intermittent shortages?
4. Is the water close enough or is there sufficient containers/storage?
5. Does the population practise good hygiene?
6. Is the source contaminated and is treatment necessary?
7. Is chlorination possible without pre-treatment, and can pre-treatment be set-up quickly?
8. Are alternative sources nearby, and can they be developed?
9. If water sources are poor, can tankering be implemented?
10. If tankering cannot be organised, should displaced be relocated?

The following flowchart from the WEDC manual describes a basic selection process for water sources and treatments in a survival stage, and whether the current site has a feasible supply:

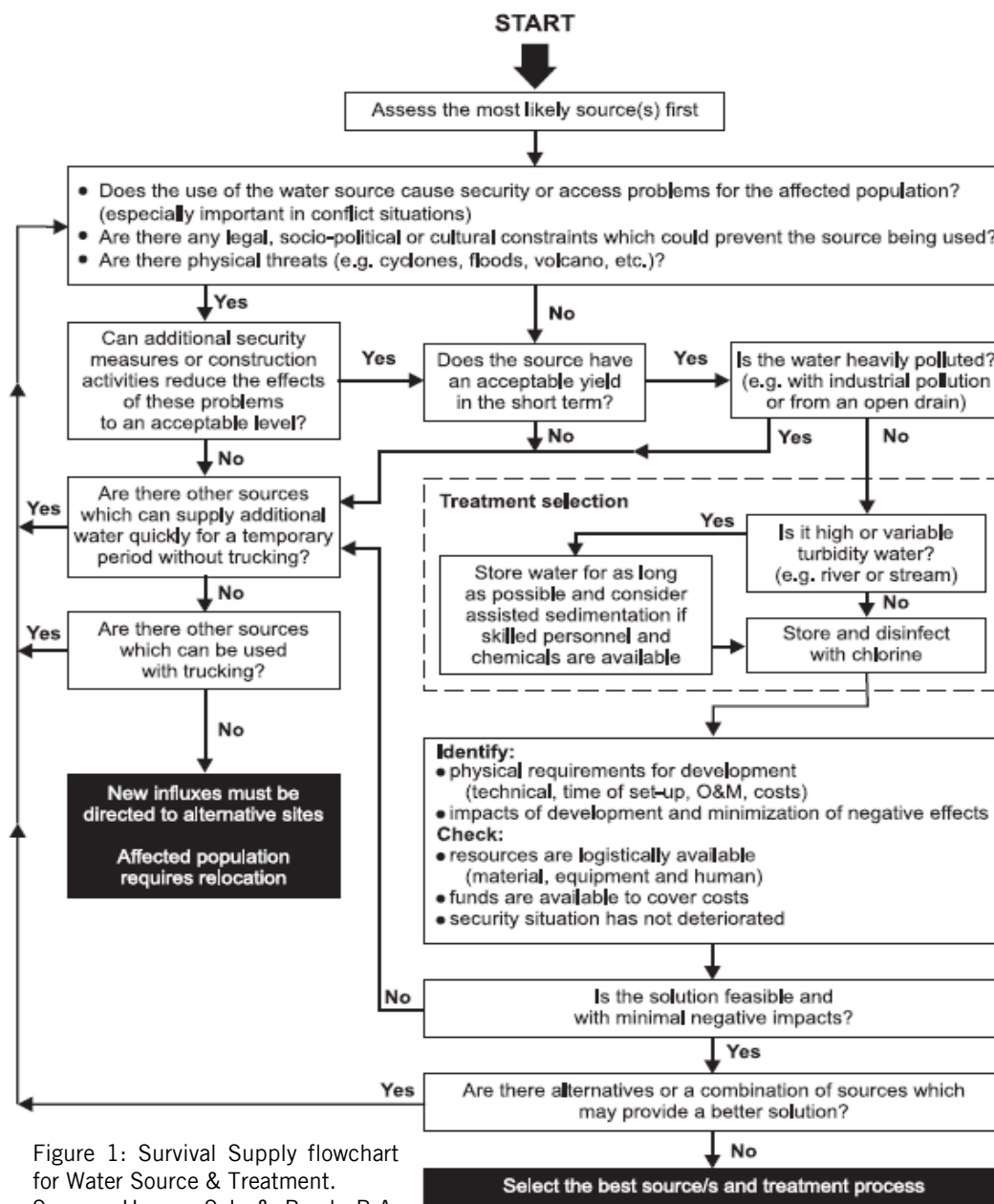

Figure 1: Survival Supply flowchart for Water Source & Treatment. Source: House, S.J. & Reed, R.A. (2004) 'Emergency Water Sources: Guidelines for Selection and Treatment'

technical brief

Standards

The SPHERE project is a collaboration of a wide range of NGOs and humanitarian agencies that has produced guidelines on the minimum standards for provisions for refugees. It recommends a minimum water supply of 20L per person per day (SPHERE, 2004). This may not be possible in the immediate response, and a stepped process may be necessary:

Time – from initial intervention	Quantity of water (litres/person/day)	Maximum distance from shelters to water points (km)
2 weeks to 1 month	5	1
1 to 3 months	10	1
3 to 6 months	15 (+)	0.5

Table 1: Suggested step response in low-supply scenario.
Source: Reed & Reed, (2011) ‘How much water is needed in emergencies?’

The UN Refugee Agency (UNHCR) has produced a publication; [A Guidance for Field Operations on Water and Sanitation](#), which details many of these standards in an emergency context.

The most basic needs for water in an emergency are for drinking, cooking and personal hygiene. Often there is a trade-off between quantity and quality, and it is important to ensure that the whole displaced population has access to sufficient water to achieve this without diluting the quality of the supply too much. A brief guide to water requirements in emergencies is available from WEDC [here](#) (Reed, B. and Reed, B. 2011), including a visualisation of the hierarchy of water needs in the reconstruction process:

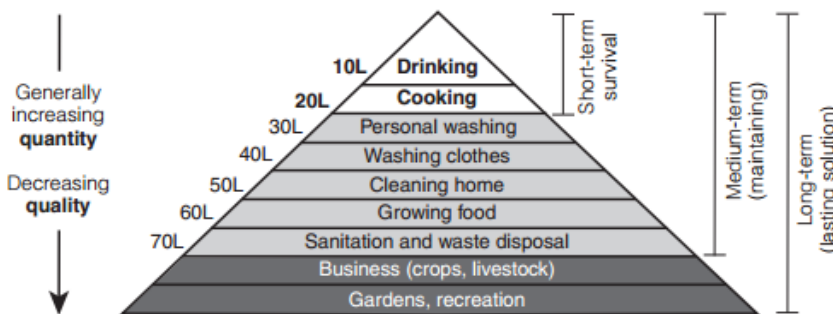

Figure 2: Hierarchy of water requirements.
Source: Reed & Reed, (2011) ‘How much water is needed in emergencies?’

In general there are four options for water supply in an emergency, with groundwater more likely to be safe; a standard assumption is that all surface water is contaminated. Both are preferable to tankering, which is expensive and difficult to organise; however, it may be necessary as an initial step. Rainwater is safe if it is available, but should only feature high in a plan if weather patterns in the area are well understood (UNHCR, 2007).

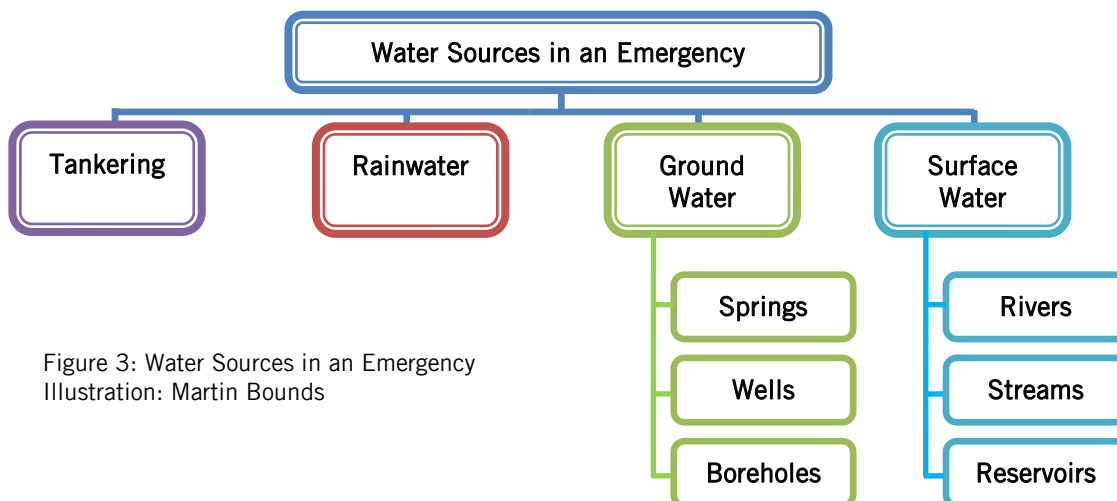

Figure 3: Water Sources in an Emergency
Illustration: Martin Bounds

technical brief

Organise tankering

Tankering involves transporting water in from external sources, and is only to be implemented if absolutely necessary, due to the huge costs and logistics involved. In some cases there may be few or no local supplies that are easily accessible, and relocation of a camp may not be possible, in which case tankering may be the only immediate supply of water. There are several key considerations for the organisation of water tankering:

- 1. Management: ensure sufficient organising, monitoring and evaluating of situation.
2. Source: identify and obtain clearance to use nearest available sources.
3. Contracts: it may be necessary to hire in a private firm to provide the service.
4. Route: establish a safe and passable route from source to distribution point.
5. Transport & Equipment: identify appropriate means of transport & required equipment.
6. Fuel: establish means of fuelling for fleet and subsequent cost.
7. Workforce: Identify workforce required for all necessary steps of process.
8. Schedule: calculate how many deliveries and when they are required.

It will also be necessary to identify how to distribute the tanked water fairly and evenly; using interim filling stations to store delivered water (see section on distribution, transport & storage). A brief guide to tankering logistics is available from WEDC (Reed, B. 2011) here.

Protect sources

If there are local groundwater and surface water sources that are available to use, it is necessary to protect them as quickly as possible, preventing contamination. This corresponds with guidelines for sanitary provision, locating latrines and washing facilities away from and downstream of water sources. It is also important to ensure that latrine facilities are located downhill from any groundwater sources.

Wells, springs, rivers and tankering collection points can all be guarded by fencing and drainage areas; the appointment of supervisory guards may well be necessary. A simple diagram of controlled access to a river water source is shown below:

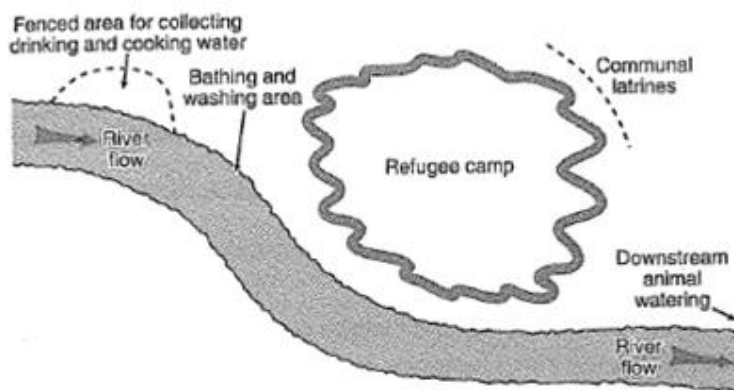

Figure 4: Controlled access to a river water source Source: Davis, J. and Lambert, R. (2002)

Provide distribution, transport and storage

It is likely that provision of water will be distributed from only a few points, which need to be carefully controlled. In keeping with the protection of sources, water should be distributed by a controlling organisation, rather than letting people collect themselves. Whilst it is important to de-centralise water supplies as the reconstruction process progresses, strict control at the beginning is necessary to prevent contamination.

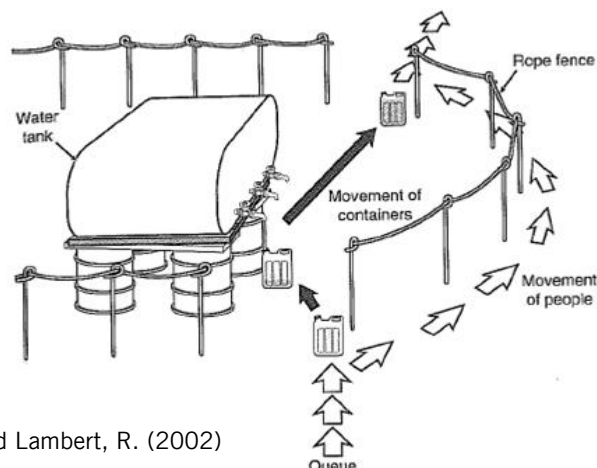

Figure 5: Water distribution point Source: Davis, J. and Lambert, R. (2002)

Water from any source can be kept in small, transportable tanks; this allows easy control and distribution to queues, and gives particulates in the water the opportunity to settle, helping with treatment. From here, it is recommended that each group of 5 people is given two collection vessels of 10-20L and one storage vessel for water (Reed, B. and Reed, B. 2011).

▪ Provide treatment

The aim of emergency responses is to provide sufficient quantities of adequate quality water, rather than small amounts of pure water (UNHCR, 2007). It is unlikely that water sourced in an emergency will be completely safe for consumption; it is standard procedure to assume all surface water is contaminated. In that respect it is essential to provide basic treatment facilities for displaced people. There are four main categories of treatment:

- Chemical Disinfection
- Storage
- Filtration
- Boiling

There should be provision to treat the water at the central distribution points and at point-of-use for individuals. A very first step is to chlorinate main supplies, with a concentration of up to 1% (UNHCR, 2008). This should kill sufficient pathogens that may be present to make the water a safe level for consumption. Additionally, if water is allowed to sit in a dark container for a day, more than 50% of harmful bacteria can die off (Kagaya, S. and Reed, B. 2011). Another benefit of this is that many of the sediments prevalent will settle, reducing the turbidity of the water and making future treatment more effective. By performing these actions at water distribution points, it should be safe enough for those collecting, although additional treatments can be undertaken.

Basic filtration devices can be used, although the development of advanced systems (such as sand-filters) takes time and will not be ready in the immediate aftermath of a disaster. One of the simplest options is the use of cloths to separate the largest particulates. Another solution that has been developed by the Sri Lanka Red Cross is the 'Clay Pot Filter', which removes a high percentage of bacteria. It is an affordable, portable method of providing families and individuals with good quality water, and is described in more detail in the Practical Action technical brief [Clay Water Filters](#).

A method of disinfection using solar rays and plastic bottles is [SODIS](#) (see Practical Action technical brief), which is simple to implement sufficient bottles and sunlight are present. Boiling provides the most effective disinfection of water but requires large energy inputs that often aren't available. WEDC provide an information sheet on point-of-use water treatment [here](#). Additionally, the Practical Action technical brief [Water Treatment during Reconstruction](#) covers appropriate solutions.

These methods can be used to encourage individual responsibility for water treatment, and are relatively easy to distribute and demonstrate. This can encourage the participation of communities at an early stage in reconstruction.

▪ Promote hygiene

The methods to ensure hygienic conditions may or may not be accustomed to the displaced population in an emergency. It is vital in the initial assessment to understand what cultural practices exist, and what needs to be communicated to people. The most important practices to focus on are:

- Appropriate use and maintenance of sanitation facilities
- Safe disposal of faeces
- Hand-washing (especially after defecation)
- Safe storage of water (i.e. cover pots)

Hygiene promotion fits intrinsically with the principles of PCR; the need to involve the community in promoting and spreading knowledge of hygienic practise is key to ensuring standards are kept up. General information on how to involve the community in decision making can be found in Practical Action's [PCR Tools](#). Additionally, WEDC provide an information sheet on basics of emergency hygiene promotion [here](#), and [Engineering in Emergencies](#) provides guidance in its 'Environmental Health' chapter.

Another approach is that of Community-Led Total Sanitation (CLTS), which aims to encourage communal responsibility for safe hygienic practise by promoting a sense of disgust about the poor disposal of human waste and faecal matter. A participatory approach is essential to the success of this method, and must include people from the very beginning. The Institute of Development Studies at Sussex University has published a guide to CLTS processes, available [here](#). Establishing a keen sense of hygienic responsibility is essential in an emergency relief context, and the inclusion of participatory approaches can translate well to later stages of the reconstruction process.

▪ Monitor and evaluate

Once the necessary infrastructure has been installed, it is vital that all areas are monitored consistently; any changes in water demand, supply or quality must be recorded and acted upon as soon as possible. Efforts should be co-ordinated with health workers to ensure that the supply isn't having a negative effect on the health of the displaced population. This is another area where the inclusion of those affected can lead to greater integration of people into participatory approaches.

This brief will now look at some basic methods of supply from rainwater, surface water and groundwater sources.

Rainwater

The size of the contribution rainwater can make to supplies in an emergency situation is highly dependent on a variety of factors:

- Local rainfall patterns
- Time of year
- Type of emergency shelter used
- Terrain
- Availability of storage

In general, an assessment should not include rainwater in its considerations, unless the local rainfall pattern can be accurately predicted. In cases where rainfall can be utilised, every effort should be made to gather as much as possible (UNHCR, 2007).

Rainwater harvest techniques generally consist of diversion, guttering and storage facilities (described in the Practical Action technical brief [Rainwater Harvesting during Reconstruction](#)); advanced techniques utilise specially designed equipment of robust design, but that is often not available in emergency scenarios.

However, the principle of directing and storing rainwater can be achieved with simple methods, such as tent canvasses leading to buckets. It may also be possible to implement more advanced rainwater harvest techniques such as guttering and first flush systems on communal buildings, which may be built with a transitional structure.

A benefit of collecting rainwater over groundwater is the improved turbidity (resulting in more efficient treatment techniques) and taste (Burt, M. & Keiru, B. 2009). Some very basic examples of RWH in an emergency are demonstrated in the pictures below:



Figure 7: basic RWH emergency collection
Source: Burt, M. and Keiru, B. (2009)

Safe drinking and washing water can be obtained from rainfall with some of the following guidelines:

- Clean collecting surface regularly
- Ensure storage facility is clean
- Possible storage containers include:
- Apply post-collection treatment such as chlorination and filtration
- Encourage people to organise their own rainwater collection

Surface Water

As stated, in an emergency the available surface water is likely to be of a low quality, having a high turbidity and level of pollution. Treatment methods such as slow-sand filters and dams are effective, but take a long time to construct. However, it is possible to supply safe surface water by applying basic filtration and treatment methods such as chlorination and coarse filtration.

Surface water can be abstracted by two main methods:

- Flow diversion
- Pumping (either direct from source or from infiltration gallery/well)

A river or stream can have its flow diverted into basic filtering devices, whereby the largest sediments can be removed and the turbidity of the water reduced. Further treatments can then be performed on the water supply before consumption.

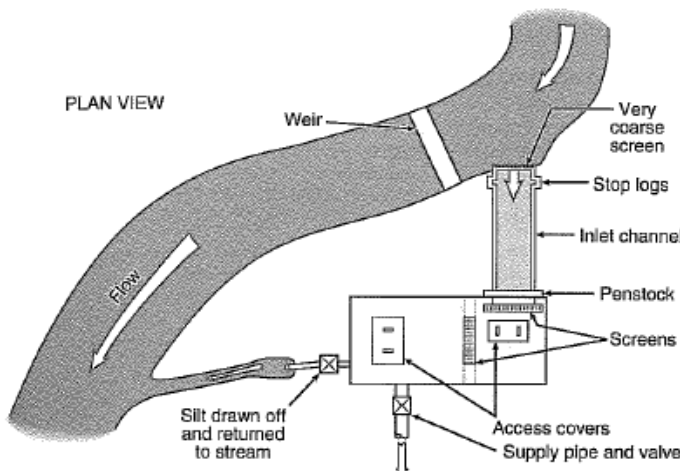

Figure 8: Diversion structure for a stream intake
Source: Davis, J. and Lambert, R. (2002)

The quality of surface water can be improved by natural filtration processes, and accessed by digging riverside wells. Alternatively, the construction of an infiltration gallery can be undertaken on the bank of a river, whereby a pump is placed in an artificial gravel bed; water pulled through the pump will be filtered by the gravel surrounding it. These solutions can be built reasonably quickly, and could compliment other water sources soon after the impact of a disaster. WaterAid have produced a guide on implementing infiltration galleries [here](#). Reservoirs do not afford the opportunity of flow diversion, but water can be pumped out and subjected to basic treatments such as storage, chlorination and coarse filtration.

Groundwater

Groundwater is water that fills natural openings in rock and sediment underground, with gravity forcing its percolation through soil until it reaches the water table. The sections of rock that store and transmit water are known as aquifers, whereas impermeable layers such as clay or bedrock are known as aquicludes. Groundwater can be accessed by the following:

- Springs
- Wells
- Boreholes

The water is often of much higher quality than surface water, due to the natural filtration processes that rock and soil formations provide. Conversely, it is usually more expensive and time consuming to access; understanding the geological nature of the terrain in an emergency situation will assist in the construction of wells and boreholes, and/or the locating of springs. It is also important to assess how much water is stored in an aquifer and what the 'recharge' (water replenishment) rate is, in order to calculate a sustainable abstraction rate. Consult [Engineering in Emergencies](#) and WEDC's guide on [Emergency Water Sources](#) for more information.

▪ Springs

Springs are an ideal source in an emergency, providing water that is likely to be of very high quality that does not need pumping. Springs can occur at diffuse seepage areas, commonly found at lower ground levels where gravity has taken water through various layers, or at point sources, which are often found at faults between layers of aquifers and aquicludes. Aquifers can be unconfined (atmospheric pressure) or confined (pressure great than atmospheric), and various geological structures can force water to the surface. An example of this is shown below:

As described in the 'Immediate Actions' section, the protection of sources is essential to ensure a sustainable supply; the following steps are commonly taken in order to protect a spring source:

- 1) Dig a drainage ditch above the spring to divert possible rainwater away from source.
- 2) Clear spring area, removing all vegetation and providing good drainage, but be careful not to disturb surrounding ground conditions.
- 3) Fence area about 10m above and around spring to control access.

Additionally, the construction of filter systems can help to remove sediments in the water. There are various methods of construction, and the chosen solution will be dependent primarily on time and cost. A relatively simple method is shown below:

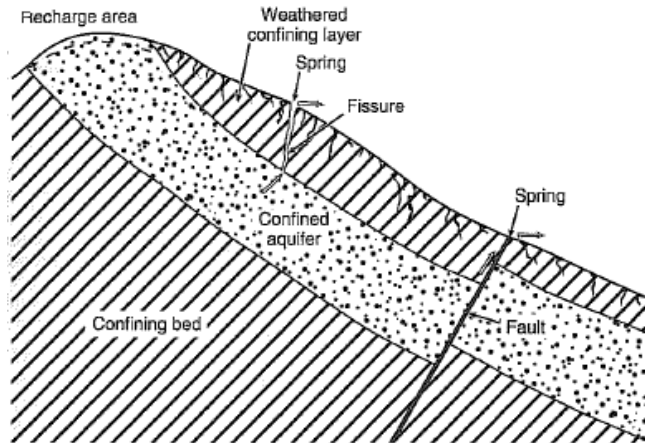

Figure 9: Spring from a confined aquifer
Source: Davis, J. and Lambert, R. (2002)

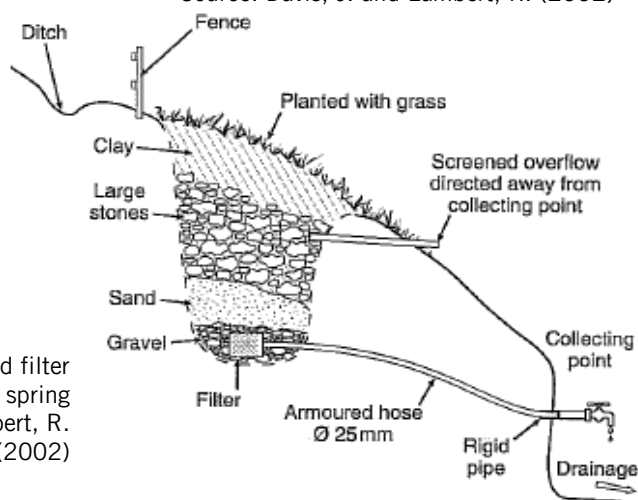

Figure 10: Protection and filter system for a point source spring
Source: Davis, J. and Lambert, R. (2002)

Wells & Boreholes

In any scenario with groundwater, it is likely that the majority of it will exist in the water table below the surface. If there are no springs, or they are not able to meet supply, wells and boreholes must be dug to reach the water.

The locating of a well can be difficult if the geology of the sub-terrain is unknown. Expertise can be sort from a hydrogeologist if available, but often it requires luck and several attempts to find an area of water table with sufficient yield. Refer to WEDC’s guide on Emergency Water Sources for detailed information and checklists on the siting of groundwater sources.

Typical Features

The picture below demonstrates the main features of a well:

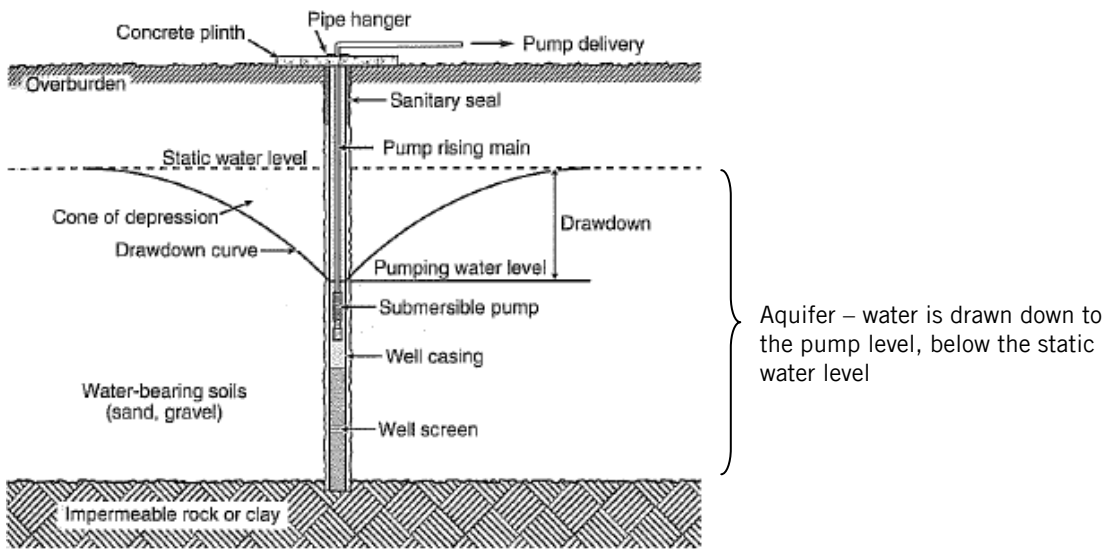

Figure 11: Schematic diagram of a typical well
Source: Davis, J. and Lambert, R. (2002)

The well will typically have a screen extending down its length into the water-drawing area, to reduce sedimentary intake to the pump. The hole will have an impermeable casing at the upper end, to prevent contamination, often made of bricks or concrete rings. The well will be sealed at the top to prevent dirty water or pollution entering. These features may differ depending on the geological conditions and the height of the water table.

Options for well construction

There are several methods for constructing a well, ranging from hand-digging to drilling with industrial machinery. The most practical method depends on a range of factors, including ground condition, supply requirements, yield, geology, manpower and machinery available.

In general, hand dug or drilled wells can be constructed quickly, requiring only manpower and simple tools. However, the depth to which they can be dug is limited to approximately 30m in normal conditions (Davis, J. and Lambert, R. (2002)). Additionally, hand-powered machinery is either slow or unable to dig through difficult ground.

Machine drilling can be much quicker, and is capable of drilling boreholes through harder ground to much deeper levels. The requirement to import specialist machinery to achieve this results in an increased cost. Drilling methods are traditionally divided into ‘percussion’ (repeated beating of ground by drill-piece) and ‘rotary’ (conventional rotation of cutting tool) drilling, although a combination of both can be used. Refer to Engineering in Emergencies for information of several methods of drilling and well lining, and their corresponding advantages and disadvantages.

The illustration beside shows a typical hand-dug well operation; the diameter of the hole being dug is typically 1.5m, which will reduce to 1.2m when a lining has been put in. Traditional tools can be complimented by simple air and water pumps, and provided that correct safety guidelines are followed, displaced people can be incorporated into the construction process.

It may be necessary to hand-dig wells to reach the closest available water, whilst waiting for machinery to be brought in to acquire access to deeper water tables for a more sustainable supply.

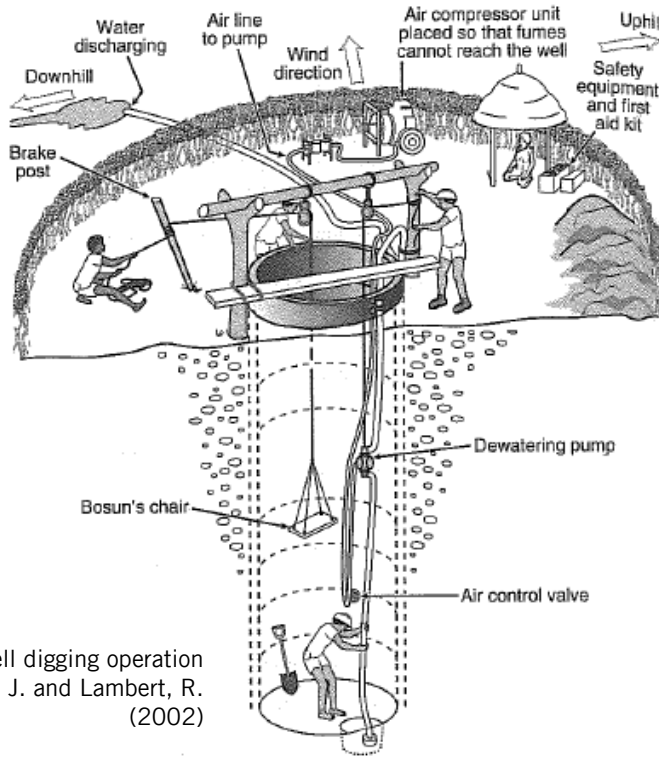

Figure 12: Safe well digging operation
Source: Davis, J. and Lambert, R. (2002)

In all methods of machine drilling a borehole, the excavated material must be 'flushed' to the surface, which can be achieved by pumping a fluid through the internal hollow of the drill string, and forcing it back up the hole; the fluid can be air, water, foam or a combination of several. The illustrations below demonstrate typical setups for percussion and rotary drilling operations.

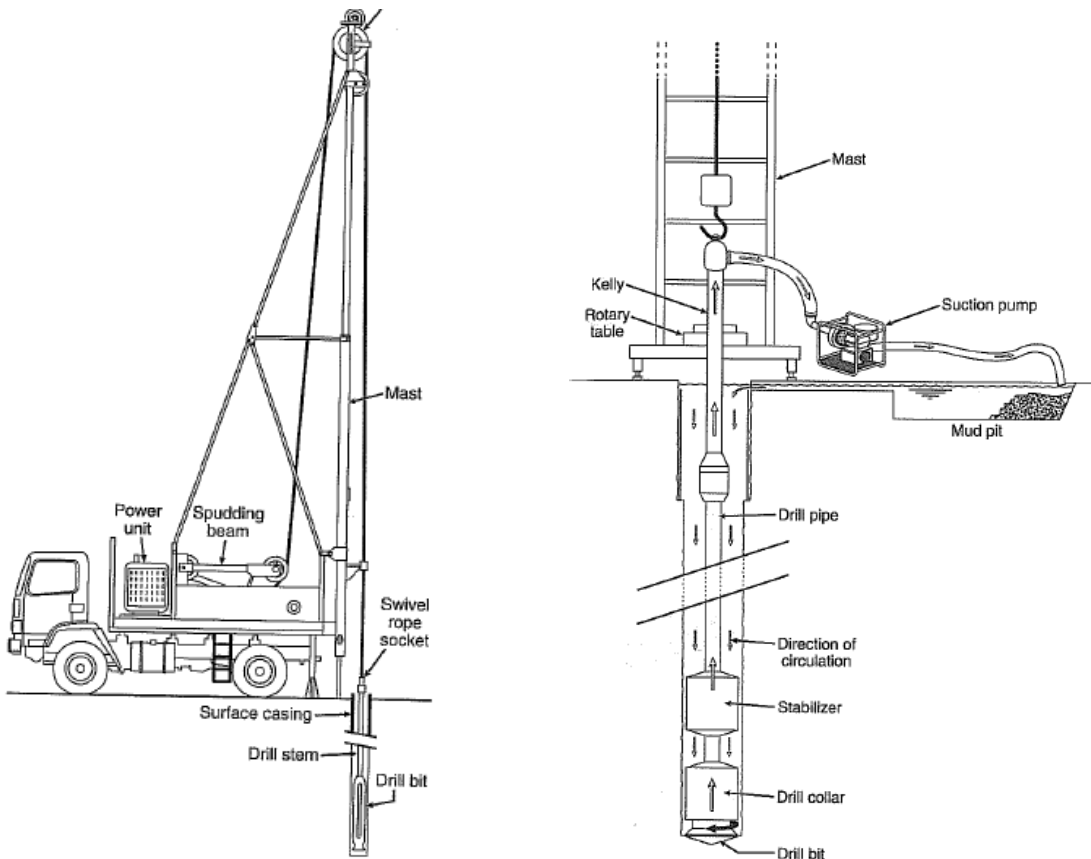

Figure 13: a) Lorry-mounted percussion drilling rig; b) Reverse-circulation rotary drilling
Source: Davis, J. and Lambert, R. (2002)

technical brief

Practical Solutions

Emergency responses are predominantly co-ordinated by humanitarian agencies, and whilst planning for PCR-based initiatives is recommended at early stages of reconstruction, it can be difficult to implement them until a stable situation has been reached. However, there are several examples of appropriate technologies that could be useful in emergency stages, encouraging community participation whilst still enabling water supplies to be secured. A selection of them is highlighted here:

Hand-powered percussion drill

A hand-powered version of a percussion drill was developed by farmers in Kassala, Sudan, in order to provide an economic and transportable method of digging wells. Much of the region suffered from water scarcity, and the majority of the population were unable to afford drilling trucks. The drill design can be constructed with a variety of materials and requires considerable unskilled labour, which can involve local products and people.

The drill could be implemented in emergency situations with relative ease, and could improve the digging of shallow wells in cases where machinery is unavailable for deep boreholes. The Practical Action technical brief [Well Digging in Kassala: The Hand-Powered Percussion Drill](#) has more details.

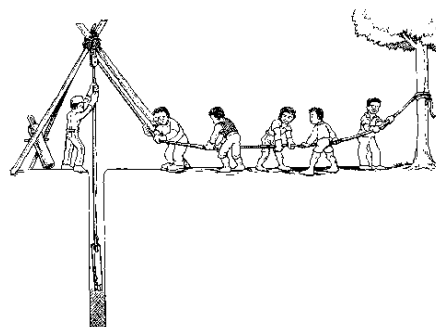

Figure 14: Principle of Hand-powered percussion drill
Source: Practical Action

Human-powered pumps

Practical Action has produced a guide on relatively simple hand pumps that cost little to install and maintain and are suited to use in areas where water infrastructure is limited.

Any shallow well that is dug in an emergency will require a mechanism to bring the water to the surface; a common solution is to use a reciprocating suction pump, which has a plunger or piston which moves up and down in a two-valve closed cylinder. As the plunger moves upward it forces water out through the outlet valve and at the same time draws water into the cylinder through the inlet valve. Moving the plunger down brings it back to its starting position. See Practical Action’s technical brief [Human-powered handpumps](#) for details.

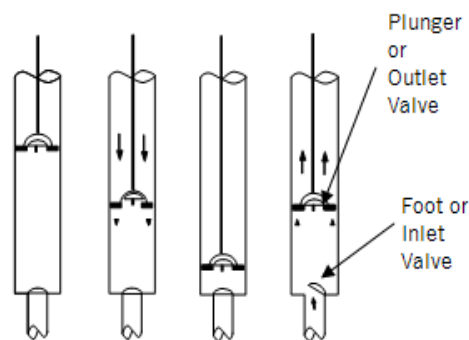

Figure 15: Suction pump operation
Source: Practical Action

Treadle pump

The treadle pump is a human-powered device that utilises two cylinders driven by a person’s legs. The twin pumping makes it more efficient than a hand pump, and leg muscles tire less easily than arm muscles. A large proportion of the device can be assembled from local materials, with only the pump itself requiring external manufacture. The pump can be used to draw up water from shallow wells, and could be used in conjunction with a hand-powered percussion drill as a practical way of locating and abstracting groundwater. This is another solution which could be implemented in emergency situations if a relief agency is unable to provide sufficient infrastructure. See Practical Action’s technical brief [Treadle Pumps](#) for more details.

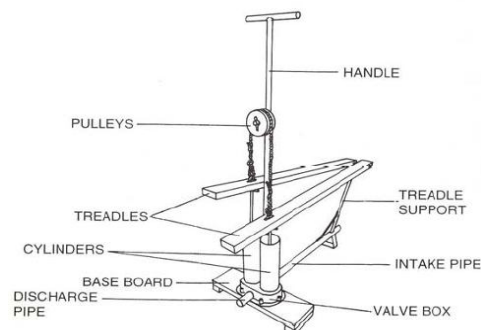

Figure 16: Treadle pump components
Source: Practical Action

technical brief

Conclusion

One of the immediate concerns in an emergency response is to ensure the displaced population has access to a safe and sufficient water supply. Humanitarian agencies will often co-ordinate process, bringing in external solutions for a rapid response. This is usually necessary at first, and people-centred solutions are not implemented until stability has been reached.

However, in some cases it may be that the required infrastructure is not available, or not sufficient to meet water needs. In this respect, the ability of displaced people to implement their own water sourcing techniques can either replace or enhance emergency responses. In a PCR process it is essential to empower people from an early stage, and if it doesn't detract from essential relief efforts, then the use of appropriate technologies is encouraged.

This brief has looked at some of the typical stages involved in supplying water in an emergency relief effort, and some of the common techniques employed by humanitarian agencies to achieve them. It has also covered examples of people-centred solutions that could also be implemented to increase community involvement and skill/knowledge sharing amongst the displaced population.

References and Further Reading

Practical Action documents:

[Clay Water Filters](#)

[Human Powered Handpumps](#)

[Rainwater Harvesting during Reconstruction](#)

[Solar Water Disinfection](#)

[Treadle Pumps](#)

[Water Treatment during Reconstruction](#)

[Well Digging in Kassala: The Hand-Powered Percussion Drill](#)

Oxfam Field Manuals

Water Distribution Manual: [URL](#)

Water Filtration Manual: [URL](#)

Water Pumping Manual: [URL](#)

Water Quality Analysis in Emergency Situations: [URL](#)

References

Burt, M. & Keiru, B. (2009), *"Innovative rainwater harvesting techniques for emergencies: Lessons from the field"*: WEDC Reviewed Paper 196. [URL](#)

Davis, J & Lambert, R. (2002), *"Engineering in Emergencies: A Practical Guide for Relief Workers"*: Practical Action Publishing, ISBN 9781853395215. [URL](#)

House, S. & Reed, B. (2004) *"Emergency Water Sources: Guidelines for selection and treatment"*: WEDC, Loughborough University, UK. [URL](#)

Kagaya, S. & Reed, B. (2011), *"Emergency treatment of drinking water at the point of use": Technical notes on drinking-water, sanitation & hygiene in emergencies No.5*: WHO & WEDC. [URL](#)

Odhiambo, F. & Reed, B. (2011), *"Hygiene promotion in emergencies": Technical notes on drinking-water, sanitation & hygiene in emergencies No.10*: WHO & WEDC. [URL](#)

Reed, B. & Reed, B. (2011), *"How much water is needed in emergencies": Technical notes on drinking water, sanitation & hygiene in emergencies No.9*: WHO & WEDC. [URL](#)

Reed, B. (2011), *"Delivering safe water by tanker": Technical notes on drinking water, sanitation & hygiene in emergencies No.12*: WHO & WEDC. [URL](#)

The Sphere Project (2004), *"Humanitarian Charter and Minimum Standards in Disaster Response"*: The Sphere Project, Geneva, Switzerland. <http://www.sphereproject.org>

UNHCR (2008), *"A Guidance for UNHCR Field Operations on Water and Sanitation Services"*: The UN High Commissioner for Refugees. [URL](#)

UNHCR (2007), *“Handbook for Emergencies”*: The UN High Commissioner for Refugees. [URL](#)

Useful Contacts & Information:

Development Technology Unit,

School of Engineering,
University of Warwick,
Coventry CV4 7AL, UK.

Email dtu@eng.warwick.ac.uk

<http://www2.warwick.ac.uk/fac/sci/eng/research/civil/crg/dtu/>

The International Water & Sanitation Centre (IRC)

P.O. Box 82327
2508 EH The Hague
The Netherlands

Tel: +31 70 3044000

Fax: +31 70 3044044

WASH Library: <http://www.washdoc.info/page/53887>

Lifewater International

Technical Library: <http://www.lifewater.org/technical-library>

Email: info@lifewater.org

Oxfam Policy & Practice Communications Team

Oxfam House
John Smith Drive
Oxford
OX4 2JY

United Kingdom

Tel: +44 (0) 1865 473727

Fax: +44 (0) 1865 472393

Email: policyandpractice@oxfam.org.uk

RedR UK

250a Kennington Lane
London
SE11 5RD

Phone: +44 (0)20 7840 6000

Fax: +44 (0)20 7582 8669

Email: info@redr.org.uk

Water, Engineering & Development Centre

The John Pickford Building
Loughborough University
Leicestershire
LE11 3TU

United Kingdom

Tel: +44 (0) 1509 222885

Fax: +44 (0) 1509 211079

World Health Organization (WHO)

World Health Organization
Avenue Appia 20
1211 Geneva 27
Switzerland

Tel: + 41 22 791 21 11

Fax: + 41 22 791 31 11

Publications: [URL](#)

technical brief

The UN High Commissioner for Refugees (UNHCR)

Strand Bridge House
138 - 142 Strand
London
WC2R 1HH
Tel: +44 (0)20 7759 8090
Email: gbrlo@unhcr.org

This document was written by Martin Bounds for Practical Action March 2012

Practical Action
The Schumacher Centre for Technology and Development
Bourton-on-Dunsmore
Rugby, Warwickshire, CV23 9QZ
United Kingdom
Tel: +44 (0)1926 634400
Fax: +44 (0)1926 634401
E-mail: inforsew@practicalaction.org.uk
Website: <http://practicalaction.org/practicalanswers/>

Practical Action is a development charity with a difference. We know the simplest ideas can have the most profound, life-changing effect on poor people across the world. For over 40 years, we have been working closely with some of the world's poorest people - using simple technology to fight poverty and transform their lives for the better. We currently work in 15 countries in Africa, South Asia and Latin America.

technical brief