



PEANUT ROASTER

Background

In urban and sub-urban areas of Sri Lanka, roadside peanut vendors are a common sight. This is because roasted peanuts are a popular snack and there is a good market. The street vendors use a small open pan with sand as a roasting agent (sand bath) to roast the shelled peanuts. The fuel sources most commonly used are gas and kerosene. These roasters are not very efficient and the sand can be harmful to the body. Medium-scale manufacturers who have access to larger amounts of capital hire bakery ovens to roast peanuts. The peanuts are spread in a shallow pan and put into the oven and roasted over a moderate heat. There are also gas fired high-cost peanut roasters available in the country. These are efficient and less troublesome (as opposed to using the other two methods) yet they are not affordable to small-scale food processors.

Practical Action South Asia's involvement in developing an appropriate peanut roaster for small scale food processors stems from a request from an NGO called *Vinivida* in 1995. One of their beneficiaries was involved in peanut roasting and had inquired about a more efficient way of doing it.

The roaster

The apparatus is basically a manually operated rotating drum that is heated externally. This structure is housed in a brick and clay construction (similar to a small-scale bakery oven). The roaster can be fabricated at any welding workshop and has no high technology components. An ordinary mason can do the installation and construction of the hearth.

This roaster does not need gas or kerosene but uses paddy husk, sawdust or peanut shells as a fuel source. This is a low cost, freely available raw material and it is also a waste product from other industries. Peanut shells are normally not re-used and disposal can be a problem. Using the shells as a fuel source alleviates the problem.

30 kg of peanuts takes 30 minutes to roast. Plus the peanuts are evenly roasted with fewer losses due to over roasting.

The roaster could also be used to roast coffee, condiments, chilli, herbs or similar commodities.

Advantages over the present equipment

- A sand bath is not used and there are no health risks.
- The continuous rotation of the drum throughout the process results in uniformly roasted peanuts
- The producer has a control over process and timing.
- A solution to peanut husk/shell disposal as well as re-using by products (paddy husks/ sawdust)
- Low fuel costs

Practical Action, The Schumacher Centre, Bourton on Dunsmore, Rugby, Warwickshire, CV23 9QZ, UK
T +44 (0)1926 634400 | F +44 (0)1926 634401 | E infoserv@practicalaction.org.uk | W www.practicalaction.org

Practical Action is a registered charity and company limited by guarantee.
Company Reg. No. 871954, England | Reg. Charity No.247257 | VAT No. 880 9924 76 |
Patron HRH The Prince of Wales, KG, KT, GCB

technical brief

- The operation of the machine is very simple and suitable for men and women.
- Can be used for a range of products
- If required, it can be converted to use firewood as a fuel source
- The machine is low in cost and efficient.

Technical Details

Material Required

The drum roaster.

An empty tar barrel (outer drum) - 1 Nos

22/24 Gauge GI sheet (inner drum) - 1 Nos

The oven and the hearth:

Bricks - 250 Nos

Fine sand - 35 Nos

Clay - 35 Nos

An empty marga tin - for hearth - 1 Nos

(with a 100mm diameter hole at the base)

Cylindrical wood or PVC Piping (for hearth) - 2 Nos

Construction

See Practical Action South Asia technical drawings

The rotating drum roaster

The Drum roaster consists of two drums.

The outer drum (the tar barrel) is fitted to the brick work. It should be fitted in a manner so that the bottom plate of the barrel is detachable. This plate has to be replaced, because the plate is exposed to the hearth and is burnt during operation.

The inner drum is made from the 22/24 Gauge GI sheet. A small portion of this drum is made similar to a drawer that is detachable for loading and unloading peanuts.

The clay oven

The brick oven is built using clay and sand mixture according to the dimensions given in drawings.

Specific requirements

The roaster needs a floor area of 1200mm x 1025mm.

Capacity

- The drum can handle a load of 5 kg of peanuts at one time. It can roast 10kg/hr.
- The roaster can also be used for other materials and the load will differ accordingly.

Operation

- The hearth (marga tin) is filled with paddy husks, sawdust & peanut shells. It is well compacted leaving a cylindrical opening at the centre (vertical) extending it horizontally at the bottom. This is done by inserting two cylindrical poles before packing with fuel source. Once the packing is complete the two poles are pulled out carefully creating two tunnel-shaped openings.
- The hearth is lit by inserting some firewood into the base of the "airways".
- The hearth is placed at the inlet of the stove which is constructed around the peanut drum roaster.
- The drum roaster is loaded with the peanuts or other food commodities (using the drawer that is detachable).

- Once the hearth is lit, continue rotating the inner drum while checking the peanuts occasionally. Allow 20 minutes of roasting before checking it and then check every 3 minutes.
- When peanuts have been suitably roasted, unload the peanuts onto a wire mesh to avoid over burning.

Maintenance

The outer drum needs to be replaced as it gets burnt and cleaned after use.

Cost

Drum fabrication: Rs. 3,500.00
 Construction & installation: Rs. 4,550.00 - 5,500.00

Note: The cost can differ depending on availability of materials and transportation etc.

References and further reading

[Peanut Processing](#) Practical Action Technical Brief

[Peanut Processing - Groundnut Huller](#) Practical Action Technical Drawing

[Peanut Processing - Making Groundnut Sweets in Sudan](#) Practical Action Video

[Small-scale Peanut Butter Processing in Tanzania](#) Food Chain Journal Number 30 June 2002, ITDG (now Practical Action Publishing).

[The Manual Screw Press for Small-scale Oil Extraction](#),

[Oil Processing: Food Cycle Technology Source Book](#) by UNIFEM,

[Principles of Oil Extraction](#) Technical Brief, Practical Action.

Engineering drawings of the Practical Action screw press are available from Practical Action Head Office, E-mail: infoserv@practicalaction.org.uk.

technical brief

Prepared by:

Practical Action South Asia
 5, Lionel Edirisinghe Mawatha
 Kirulapone
 Colombo 5
 Sri Lanka
 Tel: (94) 11 2829412
 Fax: (94) 11 2856188
 E-mail: srilanka@practicalaction.org.lk

Vinivida is an NGO that does rural development programmes. They are involved in promoting intermediate modes of transport (IMT's), rural credit schemes etc. and work with other groups in the area to develop programmes

Practical Action
 The Schumacher Centre
 Bourton-on-Dunsmore
 Rugby, Warwickshire, CV23 9QZ
 United Kingdom
 Tel: +44 (0)1926 634400
 Fax: +44 (0)1926 634401
 E-mail: infoserv@practicalaction.org.uk
 Website: <http://practicalaction.org/practicalanswers/>

Practical Action is a development charity with a difference. We know the simplest ideas can have the most profound, life-changing effect on poor people across the world. For over 40 years, we have been working closely with some of the world's poorest people - using simple technology to fight poverty and transform their lives for the better. We currently work in 15 countries in Africa, South Asia and Latin America.

Appendix

DRUM OF THE PEANUT ROASTER

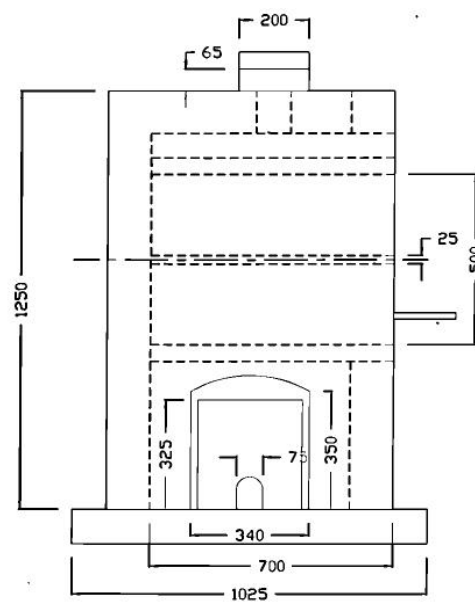
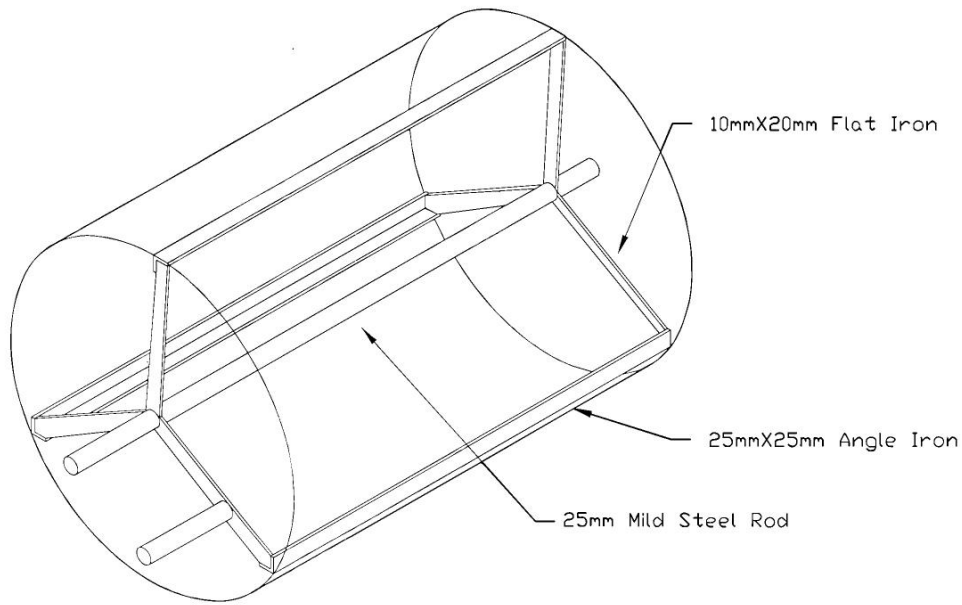

END ELEVATION

technical brief

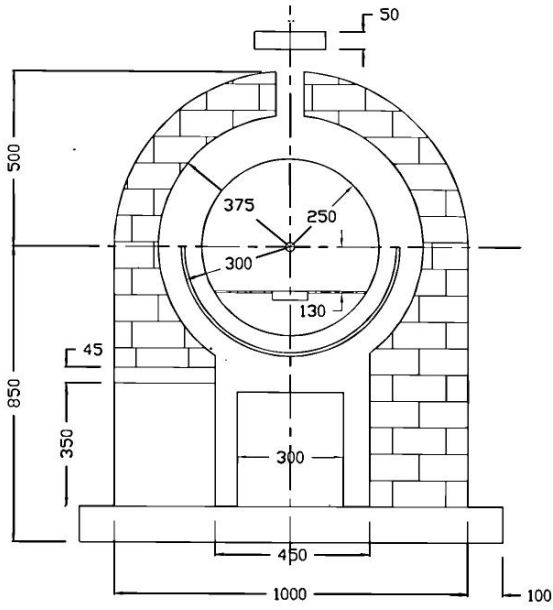

FRONT ELEVATION ON A-A

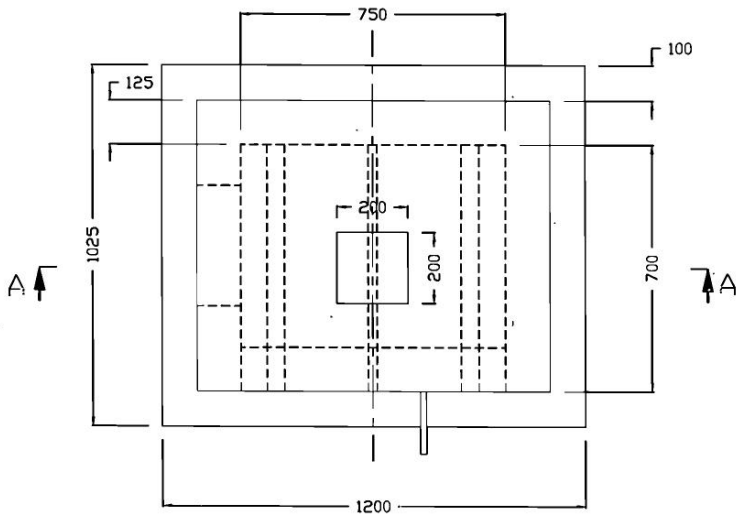

PLAN

technical brief