



# RAINWATER HARVESTING DURING RECONSTRUCTION

## Introduction

Many millions of people in the developing world do not have access to a clean, sufficient supply of water, a resource essential to almost all aspects of life. Poor people often lack the capital or technology to construct efficient water-supply systems, and make do with communal wells or rivers that are easily polluted. This situation is only compounded by disasters, which can displace populations away from infrastructure, and lead cramped, unhygienic conditions.

The concept of rainwater harvesting technology (RWH) is being developed as an affordable alternative to traditional water supply systems, helping to give people access to a naturally clean resource. A PCR process attempts to improve peoples' resilience, offering the opportunity to increase independence and participation; the planning and use of RWH within the reconstruction process from an early stage could allow people to develop and manage their own water supplies.

Whilst it is unlikely that RWH can provide all necessary water in many cases (particularly in arid areas that receive little rainfall), its use can at least alleviate the harshest effects of insufficient water supply given the right conditions.

This brief will look at the basic components and functions of a RWH system, and give details of real-world examples in practice. The relation of these different RWH technologies to the various stages of the PCR process will be developed, assessing what solutions are practical in which context. Please see Practical Action's technical brief [Rainwater Harvesting](#) for original information.

RWH technologies can generally be divided into two categories:

- Domestic
- Agricultural, erosion control, flood control (larger-scale)

## Domestic RWH

Domestic systems can be household or community based; almost all consist of a collection surface, a channelling device (gutter) and a storage facility. Additional filtration and first flush devices can also be incorporated, along with post-storage water treatments described in [Water Treatment during Reconstruction](#).

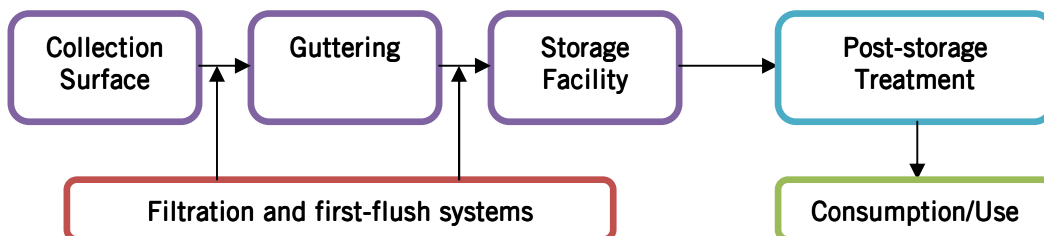

Figure 1: Schematic of RWH System, Illustration: Martin Bounds

**Collection Surfaces**

The most common form of collection surface is the corrugated iron roof; other surfaces such as tiles or thatch are also used, but are more difficult to clean and maintain. Regular cleaning of the collection surface can prevent biological contamination or pollution of the rainwater as it lands, and also reduces the workload on any filtration devices that are fitted.

Other collection surfaces can include paved walking areas and rock surfaces, particularly where underground storage facilities are used.



Figure 2: Typical Corrugated Iron Roof, Photo: Practical Action

**Guttering**

In most cases, factory-made gutters are too expensive to be considered in developing scenarios and especially in PCR contexts where local materials are preferable. Local timber can be used, but it is likely to degrade quickly, so should only be considered as a short-term measure. More durable is to use corrugated iron or steel sheet. A common technique is to use a clamp and two lengths of straight timber to hold a steel or iron sheet, which can then be bent into a V-shape. Alternatively, plastic piping can be cut in half lengthways where it is available.

It is often difficult to attach these gutters to downpipes, so they may be run straight into storage facilities if this is the case. The figures below demonstrate the technique described and some pictures of common gutter options.

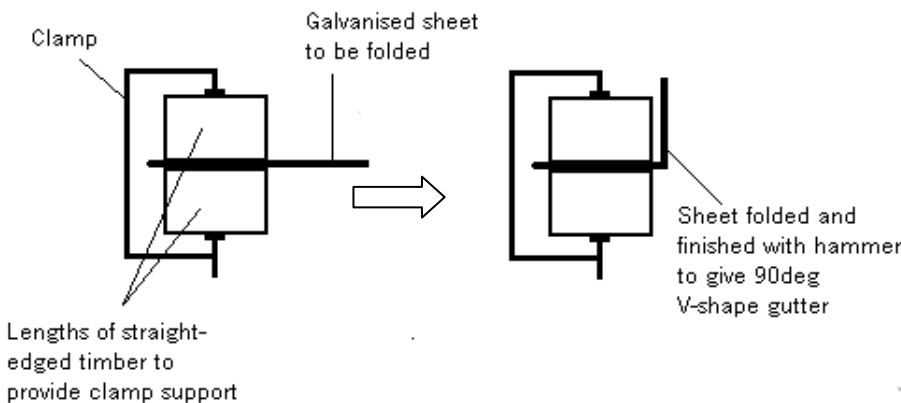
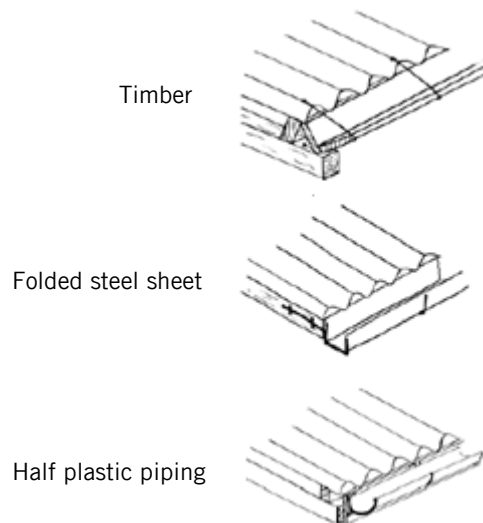

Figure 3: Simple gutter-making process  
Illustration: Martin Bounds (based on Practical Action technical brief 'Rainwater Harvesting' Ahmed, S. (2008)

Figure 4: Simple gutter fixing options  
Illustration: Martin Bounds (based on Practical Action technical brief 'Rainwater Harvesting' Ahmed, S. (2008)



Warwick University's Development Technology Unit (DTU) has produced a comprehensive guide to gutter design for RWH applications available [here](#).

technical brief

### Filtration Systems and First-Flush

It is often necessary to include filtration and ‘first-flush’ components in a RWH system, where sporadic rainfall washes debris that has collected on a roof into the guttering system. If this debris is allowed into the storage facility, it may contaminate the water in there.

Filtration may consist of a simple sand/charcoal/stone bed, which will filter efficiently but slowly due to the percolation rate through the sand. A simpler method may use a cloth or mesh to catch larger debris but prevent overflow.

More complex systems have been developed by manufacturers and are in common use in developed countries; an example is WISY, a German manufacturer that has created a downpipe filter that is approximately 90% efficient. The website can be found [here](#). A similar solution is provided by [Guttermate](#) in the UK, which is demonstrated in Figure 5. Many of these solutions are too expensive to be considered in the PCR context, and simple techniques as described may have to be used.

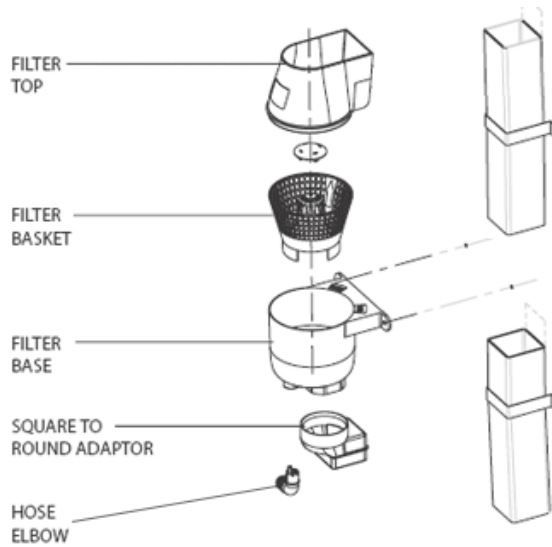

Figure 5: ‘Guttermate’ downpipe filter, Source: [www.guttermate.co.uk](http://www.guttermate.co.uk)

A first flush system can be incorporated to ensure that large amounts of debris do not block a filter or enter a storage tank after an initial rainfall following a dry period. An example is shown below, whereby a floating ball in a pre-storage tank will rise to the surface and eventually seal, diverting water directly into the storage facility.

It may be more practical in a PCR context to choose a more simple option, as it will be easier to maintain and duplicate for large displaced populations. Post-storage treatment can provide additional filtration to the stored water and ensure it is of a safe level for consumption.

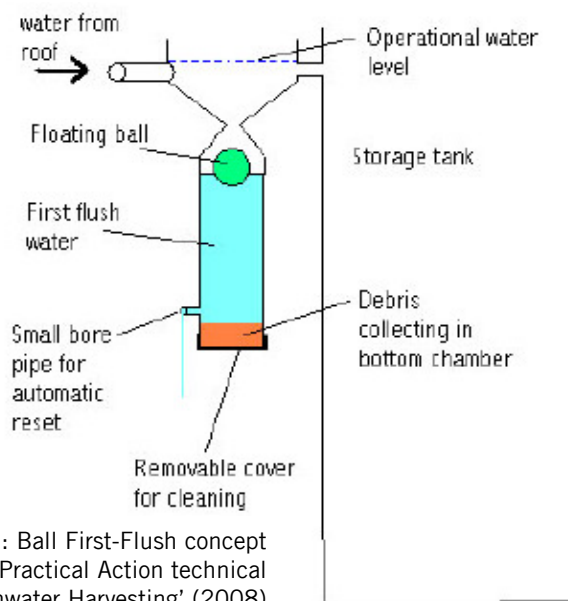

Figure 6: Ball First-Flush concept  
Illustration: Ahmed, S. (from Practical Action technical brief ‘Rainwater Harvesting’ (2008))

technical brief

### Storage Facility

The storage facility is usually the most expensive part of the RWH system, requiring the most construction and capital input. There are many types of storage, such as small clay jars or buckets, but larger vessels can generally be classified into tanks (above ground) and cisterns (below ground).

Table 1 below describes some of the advantages and disadvantages of tanks and cisterns.

<i>Tanks</i>	<i>Cisterns</i>
<p>Pros:</p> <ul style="list-style-type: none"> <li>- Above ground structure allows easy inspection for leakages.</li> <li>- Easy manufacture from a wide variety of materials.</li> <li>- Simple water extraction through gravity, and natural water pressure.</li> </ul> <p>Cons:</p> <ul style="list-style-type: none"> <li>- Generally more expensive.</li> <li>- Requires space above ground.</li> <li>- Can be damaged more easily.</li> </ul>	<p>Pros:</p> <ul style="list-style-type: none"> <li>- Generally cheaper, lower material requirements.</li> <li>- Less vulnerable to water loss.</li> <li>- Lower requirement for space above ground.</li> <li>- Unobtrusive.</li> </ul> <p>Cons:</p> <ul style="list-style-type: none"> <li>- Water extraction often requires pumping,</li> <li>- Leaks are more difficult to detect when they do occur.</li> </ul>

Table 1: Tank & Cistern Comparison

The choice of solution will normally depend on the following considerations in a PCR context:

- Space availability
- Materials & skills available locally – does a market exist or can one be created?
- Local traditions for water storage
- Cost of purchase/construction – investment vs. payback.
- Ground conditions
- Use of RWH – whether the system will provide total or partial water supply

Sizing of the solution must also be considered, based either on a demand or supply based approach. Details of this are covered in the original technical brief. Additionally, further information is available from the DTU [here](#).

### Basic Solutions

In situations where local resources are limited, and the population may not be able to afford materials to construct advanced gutters or storage facilities, an innovative approach is often required: a common material obtained by transient populations is plastic sheeting (Burt, M. and Keiru, B. 2009), which can be used to divert rainwater into buckets or pots. The sheeting is commonly used for shelter protection as well, providing a transportable, adaptable and ultra-low cost solution. An example is shown below:

More information on ultra-low cost rainwater harvesting techniques is available from the WEDC published paper [Innovative rainwater harvesting techniques for emergencies: Lessons from the field](#).



Figure 7: Basic RWH technique  
Source: Burt, M. & Keiru, B. (2009)

## Rainwater Quality & Health

There are two main issues when looking at the quality and health aspects of domestic RWH; firstly, there is the issue of bacteriological water quality. Rainwater can become contaminated by faeces entering the tank from the catchment area. It is advised that the catchment surface always be kept clean. Rainwater tanks should be designed to protect the water from contamination by leaves, dust, insects, vermin, and other industrial or agricultural pollutants.

Tanks should be sited away from trees, with good-fitting lids and kept in good condition. Incoming water should be filtered or screened, or allowed to settle to take out foreign matter (as described in a previous section). Water which is relatively clean on entry to the tank will usually improve in quality if allowed to sit for some time inside the tank. Bacteria entering the tank will die off rapidly if the water is clean.

Algae will grow inside a tank if sufficient sunlight is available for photosynthesis. Keeping a tank dark and sited in a shady spot will prevent algae growth and also keep the water cool. The area surrounding a RWH should be kept in good sanitary condition, fenced off to prevent animals fouling the area or children playing around the tank. Any pools of water gathering around the tank should be drained.

Secondly, there is a need to prevent insect vectors from breeding inside the tank. In areas where malaria is present, mosquito breeding in the storage tank can cause a major problem. All tanks should be sealed to prevent insects from entering. Mosquito proof screens should be fitted to all openings. Some practitioners recommend the use of 1 to 2 teaspoons of household kerosene in a tank of water which provides a film to prevent mosquitoes settling on the water.



Figure 8: Covered water storage in Uganda  
Photo: Practical Action

## Domestic RWH in a PCR Context

How does RWH relate to the three stages of the reconstruction process and the principles of PCR?

Rainwater harvesting cannot be relied upon in all emergency situations, but in cases where rainfall is present every effort should be made to capture it, as it provides a clean, safe source at low cost (UNHCR, 2007). Methods in an emergency stage are usually basic, most commonly consisting of plastic sheeting directing water to buckets; the resources and time required to implement more advanced systems are generally not available until later on in the reconstruction process.

Transitional shelters afford more opportunity to capture rainfall, generally being occupied for longer periods. The construction of simple pots with sheeting as a catchment is a mobile solution that doesn't require much capital or labour investment. However, the ability to capture fresh rainwater and to manage its use over periods of time can be developed to a much greater extent in the permanent housing stage of reconstruction; a key aim of PCR is to decentralise infrastructure and to give people more independence over controlling their water supply.

Individual housing units that are permanent constructions have much more opportunity to invest in more complex harvest systems, with more time to experience the benefits and to understand and adapt to changing rainfall patterns. The greater space that comes with individual dwellings allows for the construction of tanks or cisterns, and guttering can be added to well-constructed permanent houses. The construction of harvest systems has potential to open up local markets, improving living conditions and livelihoods at the same time, whilst also reducing vulnerability to potential future droughts.



Practical Action’s reconstruction work in Sri Lanka following the December 2004 tsunami saw the inclusion of RWH technologies with several dwellings. An example of this is shown in this picture here:



More information on the post-tsunami work in Sri Lanka can be found [here](#).

Figure 9: Owner-built RWH storage in post-tsunami Sri Lanka  
Photo: Practical Action

## Case Studies - Domestic

### Cement Mortar Jar

This cement jar is relatively simple to construct and has been implemented in several places in Asia and Africa. The construction process consists of a template ‘bag’ made from hessian sacking or similar material, which is placed on a concrete base and filled with sand to fill out the shape. Once full, cement mortar is plastered on, and once set the jar is emptied and the bag removed from inside. The inner walls can then be smoothed and strengthened with more mortar and cement slurry. The jar requires a 2 week cure time before it is ready to use.

The jar uses cheap materials that are readily available in many places, and can be scaled to any size. However, construction requires greater craftsmanship as size increases, along with decreased mobility. The jar could easily be fed by guttering, but it is difficult to incorporate a spigot or other access valve into the design. However, in the absence of more sophisticated storage facilities it can be a cheap and effective method.

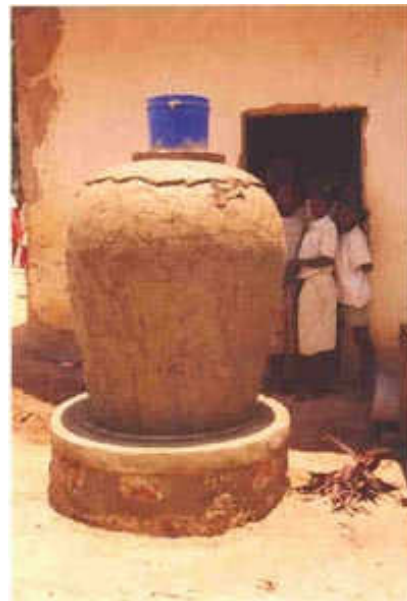

Figure 10: Cement Mortar Jar in Tanzania  
Photo: Practical Action

See the Practical Action technical brief [Cement Mortar Jar](#) for details and further reading.

### DRIP Project in Uganda

The DRIP project was formed by a small team of volunteers from near Liverpool in the UK. It was started in Uganda in response to increasingly unpredictable rainfall, which was making it more difficult for farmers to grow crops, and food supplies were therefore running low. A cheap and effective method of rainwater harvesting from thatched grass roofs was developed to allow farmers to take advantage of infrequent, heavy rainfalls, securing a water supply that could be used during dry months.

Water collected by the roof was diverted through metal guttering into a 1500L storage tank constructed with local bricks and cement render. Water stored in the tank was limited to irrigation purposes, specifically the local gardens to improve food production. A corrugated iron cover was fitted to the tank to prevent debris and insects from entering the water, and to prevent mosquitoes from breeding in there.



Additionally, the project offered educational sessions to the population, teaching the construction technique and knowledge of irrigation. This resulted in the technology being taken up on a broader scale in the area, increasing food production amongst individual families and developing community participation. The benefits experienced by many areas of the community can easily be translated to a reconstruction context, where the independence and security afforded by the solution can be incorporated into permanent housing solutions.

Refer to the Practical Action technical brief [Rainwater Harvesting in Uganda](#) for more details.

Figure 11: Construction of DRIP water tank in Uganda  
Photo: Practical Action

### Sri Lankan Pumpkin Water Tank

The Community Water Supply and Sanitation Programme (CWSSP) that ran in Sri Lanka between 1995 and 1998 installed infrastructure in three regions of country, and in many cases provided ‘Pumpkin’ tanks as above ground storage options where ground conditions were not suitable to build an underground tank or access a groundwater supply.

The Pumpkin tank described here consists of a metal ‘skeleton’ which supports a chicken-wire skin. The skin is plastered with cement outside; once set, the internal skeleton is removed and the inside plastered too. The guttering system is made from PVC tubing and includes a ‘first-flush’ elbow mechanism, whilst the tank’s inlet chamber includes layers of stone, charcoal and sand to act as a pre-filter.

The rainfall pattern of the areas where the tank was installed consisted two annual wet seasons, where the majority of rainfall would occur. The capacity of the tank was 5m<sup>3</sup>, which gave sufficient capacity upon being filled for most users until the subsequent rainy season. In this case, the technology has provided nearly enough potable water for its users’ annual supply, being used for drinking (after boiling), cleaning and cooking. Local materials were used and the labour required could be sourced locally.

Refer to the Practical Action technical brief [The Sri Lankan Pumpkin Tank: A Case Study](#) for details. There is also a technical brief on general construction techniques for [ferrocement pumpkin tanks](#).



Figure 12: Construction of Pumpkin water tank in Sri Lanka  
Photo: Practical Action

technical brief

### Brick Dome Water Tank

Another example of RWH technology installed by the CWSSP in Sri Lanka is the Brick Dome tank, which was an underground cylindrical brick construction (in some respects actually a cistern) used to store rainwater directed from the rooftop of a dwelling by U-section plastic guttering. Water in the tank was accessed by a simple hand-pump, or by a bucket.

The tank was installed as an alternative to the occupants using a communal hand-pump per every 10 households. A full tank could supply the family during dry seasons, provided they managed water use carefully.

The main issue with installation of this technology was the lack of compatibility with local customs; the occupant family of the dwelling in this case had not used RWH before, and were initially reluctant to do so. However, over an extended period of time the benefits were realised and use of underwater brick dome tanks in conjunction with RWH increased.

For more details refer to the Practical Action technical brief [Brick Dome Water Tank](#). There is also a more general brief on the design and build of cisterns in [Underground Rainwater Harvesting](#).

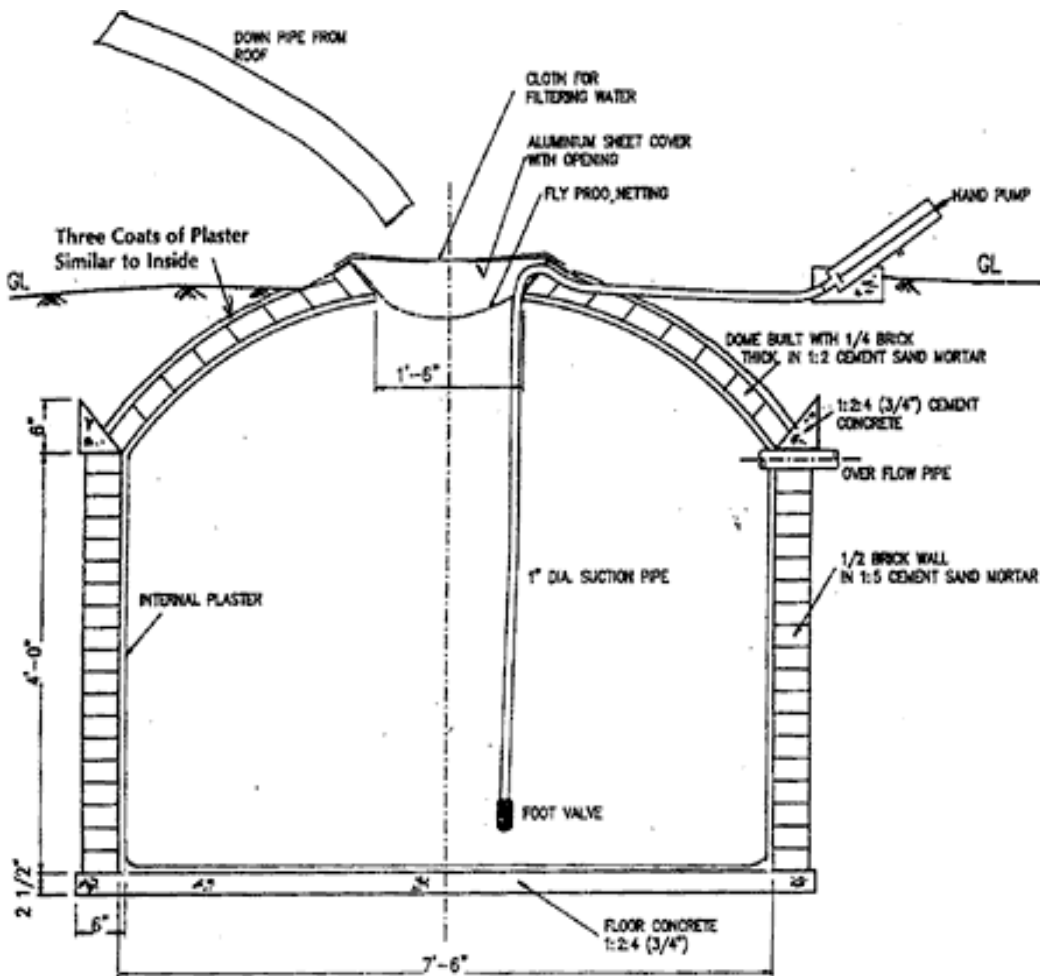

Figure 13: Section of Brick Dome water tank  
 Photo: Practical Action

Warwick University’s DTU has produced a technical guide on *partially* below-ground brick tanks, available [here](#).

technical brief



## Large-Scale Solutions

### Run-off Rainwater Harvesting

Run-off rainwater harvesting involves collecting rainwater flowing along the ground into underground storage tanks. The solution is particularly suited to areas which see concentrated, heavy rainfall for a short period annually; large volumes (up to 12,000 litres) can be held for irrigation purposes during extensive dry seasons.

A large brick pit is dug to house an underground brick tank, which is lined with cement and fed by an inlet, placed in the direction of surface water flow. Construction of the large brick tank requires significant construction and materials, and the workmanship must be of a high quality to withstand the pressure of such large volumes of water.

Whilst being able to hold significant amounts of water, there are several limitations with this technology; it requires certain geological conditions, rainfall patterns and skill sets that may not be present in emergency situations; the time and investment required are long term considerations. Consequently, it is generally suited to permanent reconstruction stages.

Practical Action South Asia has produced a technical brief [Runoff Rainwater Harvesting](#) on the subject.



Figure 14: Runoff rainwater harvest tank  
Photo: Practical Action South Asia

### Harvesting Dams

The concept of harvesting rainwater isn't limited to using dwelling roofs; in many arid and semi-arid areas the local rivers are trickles for much of the year, yet experience high water flows during intense periods of rainfall.

The inability of local populations to irrigate their lands leads to shortages in fertile soil and hence food supplies. The large volumes of water that pass in flooding season are not utilised, instead often causing damage to communities.

Constructing dams is one way to capture and use large quantities of water for irrigation and consumption. Water can be directed through the use of canals and channelling pipes to provide adequate amounts of floodwater for agricultural land. Alternatively, water can simply be stored and then collected for various uses.

Practical Action has worked in several areas of Western Sudan to construct water harvesting dams, and a detailed overview of these projects is available in the manual [Building Small-Scale Water Harvesting Dams](#). The figure below is taken from the report, and shows a landscape plan for the Shangili Tobaya dam installation, including diversion canals and water courses.

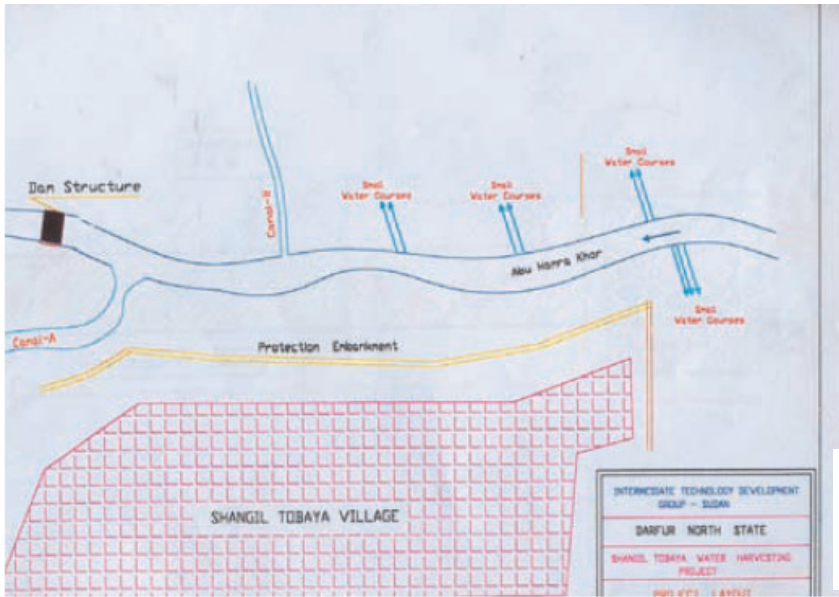

Figure 15: Plan of Shangili Tobaya Dam Project in Western Sudan  
Photo: Practical Action

Projects are large-scale community investments, requiring planning, labour, materials, training and maintenance. It is highly unlikely that there will be sufficient resources in an emergency or transitory stage of reconstruction to consider the construction of a dam. Additionally, the benefits would not be experienced until a rainy season has arrived.

However, it is clear from the experience of Practical Action’s work in Western Sudan that a sensibly sited and correctly maintained dam can revitalise agricultural land for a community. A consideration early on in the reconstruction process could be to site redevelopment close to an area where construction of a water harvesting dam could be possible. The inclusion of local, displaced people in the process is essential, and adequate training could be provided over time to ensure they can take charge of the project.

**Sand Dams**

High water flows in such areas often carry large quantities of sand downstream, which can get trapped behind rocks and act as a natural water filter; the water which is ‘cleaned’ by this occurrence is usually safe for drinking. It is possible to artificially enhance this process with a ‘Sand Dam’, which increases the amount of water filtered and trapped for consumption.

The concept involves creating a concrete wall across a river path, which directs and traps the sand; this creates a sub-surface water bank for harvesting.

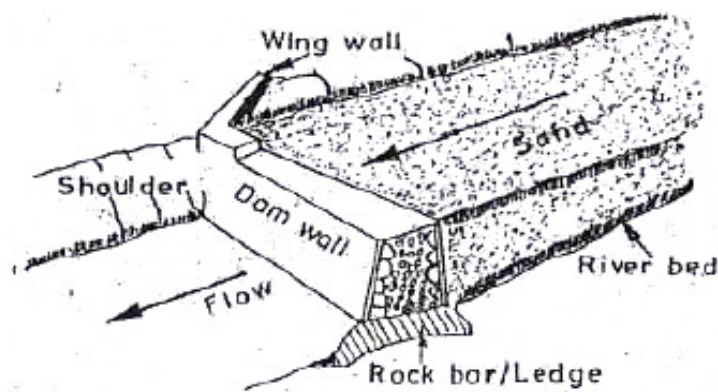

Figure 16: Diagram of Sand Dam  
Photo: Practical Action

Despite the technology being lower cost than normal rainwater harvesting dams and easier to implement in the reconstruction process, sand dams can only be constructed in areas where sandy riverbeds receive seasonal floodwaters. The level of labour required for their construction is still high, and to involve local populations will involve training if new to the concept.

Practical Action’s East Africa office has produced a technical brief detailing the basics of the technology; refer to [Sand Dams](#).

## Conclusion

The concept of RWH has been around for centuries, and comes in a wide variety of formats, from simple buckets to large industrial-scale collection systems for developed world scenarios. In developing countries, it can be of vital importance in helping to secure supplies of clean water, or to irrigate tracts of land that have previously been arid and unusable.

Reconstruction processes are different for each post-disaster scenario, and there are several factors which must be considered before deciding which RWH technologies might be appropriate; these can include (but are not limited to) materials, labour, geography, climate and social customs.

There are clear benefits to installing domestic RWH systems with permanent housing solutions, allowing families to increase water security, with the possibility of combining practical treatment technologies to ensure water is safe and clean for consumption. Basic storage and filter options could be considered appropriate for transitional stages.

More large-scale installation such as harvesting dams require considerably more investment and community involvement, but can lead to great improvements in the fertility of local land, which is vital for food security. These solutions can be considered at an early stage in the reconstruction process, with a view to implement them once the required infrastructure and investment is attained.

The technologies covered in the brief highlight some of the options available, but there are several other organisations developing solutions in the field, some of which are listed in the resources below:

## References and Further Reading

### Practical Action Technical Briefs:

[Brick Dome Water Tank](#)  
[Building Small-Scale Water Harvesting Dams](#)  
[Cement Mortar Jar](#)  
[Ferro cement Pumpkin Tanks](#)  
[Rainwater Harvesting](#)  
[Rainwater Harvesting in Uganda](#)  
[Runoff Rainwater Harvesting](#)  
[Sand Dams](#)  
[The Sri Lankan Pumpkin Tank: A Case Study](#)  
[Underground Rainwater Harvesting](#)  
[Water Treatment during Reconstruction](#)

### References:

Burt, M. & Keiru, B. (2009), *“Innovative rainwater harvesting techniques for emergencies: Lessons from the field”*: WEDC Reviewed Paper 196. [URL](#)

Davis, J & Lambert, R. (2002), *“Engineering in Emergencies: A Practical Guide for Relief Workers”*: Practical Action Publishing, ISBN 9781853395215. [URL](#)

Gould, J. & Nissen-Petersen, E. (1999), *“Rainwater Catchment Systems for Domestic Supply”*: Practical Action Publishing, [URL](#)

Rees, D. (2000), *“Partially Below Ground (PBG) tank for rainwater storage”*: Development Technology Unit TR-RWH01, University of Warwick. [URL](#)

Thomas, T.H. (1997), *“Guttering Design for Rainwater Harvesting”*: Development Technology Unit Working Paper no.50, University of Warwick. [URL](#)

UNHCR (2007), *“Handbook for Emergencies”*: The UN High Commissioner for Refugees. [URL](#)

**Useful Contacts:****Development Technology Unit,**

School of Engineering,  
University of Warwick,  
Coventry CV4 7AL, UK.  
Email dtu@eng.warwick.ac.uk

<http://www2.warwick.ac.uk/fac/sci/eng/research/civil/crg/dtu/>

- a number of case studies from around the world, with good descriptions.

Contact Dr Terry Thomas. Also the co-ordinators of the Rainwater Harvesting Research Group (RHRG) <http://www2.warwick.ac.uk/fac/sci/eng/research/civil/crg/dtu/rwh/links/>

**Guttermate**

UK-based manufacturer of rainwater filtration and storage products

<http://www.guttermate.co.uk/>

**WISY**

German manufacturer of rainwater filtration and storage products

<http://www.wisy.de/eng/eng/products.htm>

**International Rainwater Catchment Systems Association (IRCSA)**

Dept. of Natural Resources, Chinese Cultural University, Hwa Kang, Yang Min Shan, Taipei, Taiwan.

E-mail: ufab0043@ms5hinet.net

Website: <http://www.ircsa.org/>

IRCSA Fact sheets <http://www.ircsa.org/factsheets.htm>

**Lanka Rainwater Harvesting Forum (LRWF)**

c/o Practical Action South Asia,  
5 Lionel Eridisinghe Mawatha, Colombo 5, Sri Lanka

E-mail: rwhf@itdg.lanka.net

Website: <http://www.rainwaterharvesting.com>

**Centre for Science and Environment (CSE)**

41 Tughlakabad Institutional Area, New Delhi 110062, India

E-mail: [cse@cseindia.org](mailto:cse@cseindia.org)

**People for promoting Rainwater Utilisation**

1-8-1 Higashi-Mukojima, Sumida City, Tokyo, Japan

E-mail [murase-m@tc4.so-net.ne.jp](mailto:murase-m@tc4.so-net.ne.jp)

**IRC (The International Water and Sanitation Centre)**

PO Box 93190, 2509 AD

The Hague, Netherlands

E-mail: [general@irc.nl](mailto:general@irc.nl)

Website: <http://www.irc.nl>

**Uganda Rain Water Association (URA),**

P. O. Box 20026, Kampala, Uganda.

E-mail: [wesacc.dwd@imul.com](mailto:wesacc.dwd@imul.com)

**Kenya Rainwater Association**

P O Box 72387, Nairobi, Kenya

E-mail: [kra@net2000ke.com](mailto:kra@net2000ke.com)

**United Kingdom Rainwater Harvesting Association**

Website: <http://www.ukrha.co.uk>

**JRCSA (Japan Rainwater Catchment Association)**

<http://takeyam.life.shimane-u.ac.jp/jircsa/homepage.html>

**SA WATER (South Australian Water Corporation)**

<http://www.sawater.com.au/sawater/>

technical brief



**Centre for Science and the Environment (CSE)**

<http://oneworld.org/cse/html/cmp/cmp43.htm>

Rainwater harvesting page - a very active Indian Group

**Sunstove**

<http://www.sungravity.com/>

The Sunstove Organization's web site provides free instructions, photos, drawings and specifications to build a roof catchment system, sand filter, cement water tank, and spring capping systems

**Global Applied Research Network (GARNET)**

<http://info.lut.ac.uk/departments/cv/wedc/garnet/tncrain.html>

Site of the Global Applied Research Network (GARNET) Rainwater Harvesting Page –

<http://www.unep.org/publications/> - link to a recent UNEP publication titled 'Sourcebook of Alternative Technologies for Freshwater Augmentation in Small Island Developing States' that includes some useful information on RWH

<http://www.unep.or.jp/ietc/Publications/TechPublications/TechPub-8e/index.html>

Sourcebook of Alternative Technologies for Freshwater Augmentation in Some Countries in Asia - another in this series of UNEP publications

**World Meteorological Organisation (WMO)**

<http://www.wmo.ch/>

**Rainwater Harvesting in the Loess Plateau of Gansu, China - a paper presented at the 9th IRCSA Conference in Brazil**

<http://www.greenbuilder.com/sourcebook/Rainwater.html#CSI> - Sustainable Building Sourcebook Website

This document was written by Martin Bounds for Practical Action March 2012

Practical Action  
The Schumacher Centre  
Bourton-on-Dunsmore  
Rugby, Warwickshire, CV23 9QZ  
United Kingdom  
Tel: +44 (0)1926 634400  
Fax: +44 (0)1926 634401  
E-mail: [inforserv@practicalaction.org.uk](mailto:inforserv@practicalaction.org.uk)  
Website: <http://practicalaction.org/practicalanswers/>

Practical Action is a development charity with a difference. We know the simplest ideas can have the most profound, life-changing effect on poor people across the world. For over 40 years, we have been working closely with some of the world's poorest people - using simple technology to fight poverty and transform their lives for the better. We currently work in 15 countries in Africa, South Asia and Latin America.