



**Intermediate Technology Development Group
Zimbabwe**

Technical Advice Notes Number 2

HOW TO MAKE STABILISED SOIL BLOCKS

(SSB'S)

HOW TO MAKE STABILISED SOIL BLOCKS

Earth or soil has been used to make buildings all over the world for thousands of years. Many earth buildings have stood for hundreds of years. The main enemy of earth buildings is water. Both rain and rising groundwater or moisture can damage earth structures.

Here we are dealing with making stabilised soil blocks. The making of these blocks deals with the two main problems that can happen with earth buildings:

Stabilisation: Adding something to the earth that helps to make it more resistant to attack by water, something that helps "waterproof" the earth. Stabilisation can also increase strength.

Compaction: Pressing the earth makes it stronger in "compression", that is it allows earth walls to take more weight on them without collapsing. Making earth into blocks is also a way to make stabilised earth into a form that can more easily be used by builders.

These notes are to help anyone who wants to make SSB's. The notes concentrate on stabilising soil with cement and building lime is mentioned as an alternative for some soils.

The most common type of cement available is Ordinary Portland Cement (OPC). If lime is used as a stabiliser, it should be hydrated lime building lime. Hydrated lime is made by burning limestone in a very hot fire (900°C). Burning produces quick lime. An exact amount of water is then added to produce hydrated lime. The lumps formed are then ground to a powder for easy use.

The notes cover all the stages in the making of SSB's that is:

1. Soil testing - choosing which stabiliser & how much to use.
2. Soil preparation - crushing, sieving and mixing.
3. Block pressing - correct wetness and amount to put in press.
4. Block curing - how to keep the blocks after pressing.
5. Block testing - tests to do yourself and others that can be done.

SOIL TESTING

There are two groups of tests worth doing. Group 1 will help you to get a feel for the soil, but not tell you if it is a good one for stabilisation unless you are very experienced. Group 2 are two simple tests that will tell you enough about the soil to see if it is okay for making SSB's, how much and which stabiliser to use.

To use cement as a stabiliser you are probably looking for a soil which is less than 1/5 (20%) silt and clay. In other words, you want a sandy soil which preferably has a good mixture of particle sizes from medium gravel (about 6mm - millimetres - diameter) to fine sand (0.06mm diameter). Soils with higher clay contents can be stabilised but need more cement, or hydrated lime can be used.

Technical Advice Notes Number 1, "How To Find A Good Soil For Making Burnt Bricks", will tell you how to get a soil sample for testing.

GROUP 1

(a) **TOUCH TEST:** Take some dry soil that is not in lumps and feel it between your thumb and fingers. If it is very gritty and sharp this means that there is a lot of sand. If it is smooth and powdery (like white flour or talcum powder) then there is a lot of clay and silt. Make a note of the colour of the soil, any lumps, stones or different coloured deposits.

(b) **SCRATCH & POLISH TEST:** If possible, take a small lump of the soil and scratch it with your thumb nail. If it is a fine soft powder that comes off then the soil is high in clay. If the lump crumbles easily and gritty pieces come off, this means high sand.

Now try to polish the lump with the back of your thumbnail. It may help if you wet your nail a little. If you can polish the surface to a nice shine this means that there is a lot of clay in the soil.

(c) **TONGUE TEST:** If you put your tongue onto the surface of the lump that you have smoothed, you might notice that it sticks. The more your tongue sticks the more clay there is in the soil. Remember you want a soil with only a little clay for making a strong and cheap SSB with OPC.

(d) **ROLLING TEST:** Take a little of the powdered soil in the palm of one hand. Wet it a little so that it sticks together. If it sticks together well, and you can shape it and roll it into a thin thread then there is clay in the soil.

Take your wetted soil and try to roll a thread on some flat clean surface. If you can roll a thread less than 3 millimetres in diameter, then there is probably too much clay in the soil to make stabilised blocks well and cheaply.

(e) **DROP TEST:** Take a wetted lump of the soil and mould it in your hands, the soil should not be so wet that water can be squeezed out. Drop a lump that just fits into your one hand onto a hard surface from shoulder height. If the lump stays in one piece, there is probably a lot of clay in the soil. If, on the other hand, the lump breaks up into a few smaller pieces there is probably quite a lot of sand.

GROUP 2

(a) **SEDIMENTATION JAR TEST:** Pass some of the soil through a sieve with 5 or 6 millimetre mesh (an ordinary kitchen strainer is usually okay). Take a straight sided clear glass jar and fill it one-third full with the sieved soil. Add water until the jar is $\frac{2}{3}$ or $\frac{3}{4}$ full. Shake the well for one or two minutes. Place the jar on a flat surface. After about half an hour the soil will have settled, have a look at it and then shake it up again well. Leave the jar to settle overnight.

Sometimes it helps to add a little salt ($\frac{1}{2}$ or 1 tea spoon) to the jar because this helps to separate the clay from the sand.

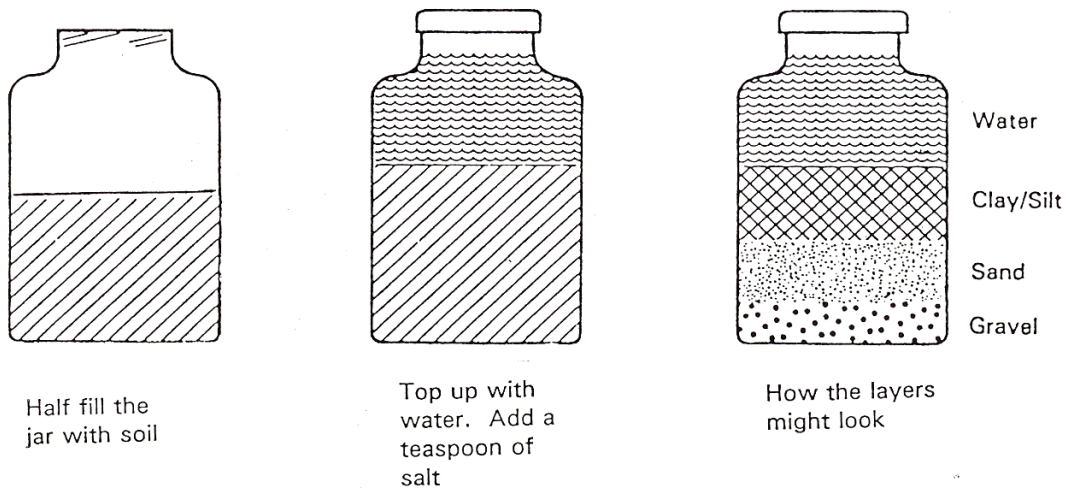

Hopefully the soil will separate out in layers as shown above. Measure the height of the different layers and write down your results. From the measurements you can find the approximate proportions of the different parts of the soil.

HOW TO UNDERSTAND THE RESULTS:

If a soil has 10% (1 tenth - 1/10) clay (the minimum necessary for it to stick together enough to make blocks) it may only need 5 % OPC to stabilise (1 part cement to 19 parts soil - 1: 19). For a soil with 30% (almost 1/3) clay, 10% or more cement will be needed (1:9). More clay than this usually means that it will be too expensive to stabilise the soil with OPC, lime can then be considered.

EXAMPLE: If the heights are: Gravel 15mm; Sand 25mm; Clay 8mm and silt 2mm. Then the proportions are as follows:

Total: $15 + 25 + 8 + 2 = 50\text{mm}$ (equivalent to 100%)

Gravel: $15/50 \times 100 = 30\%$

Sand: $25/50 \times 100 = 50\%$

Clay: $8/50 \times 100 = 16\%$

Silt: $2/50 \times 100 = 4\%$

(b) **SHRINKAGE MOULD TEST:** For this test you will need a mould called a linear shrinkage mould. The mould can either be made from wood or metal. The plan shown below is for a wooden mould.

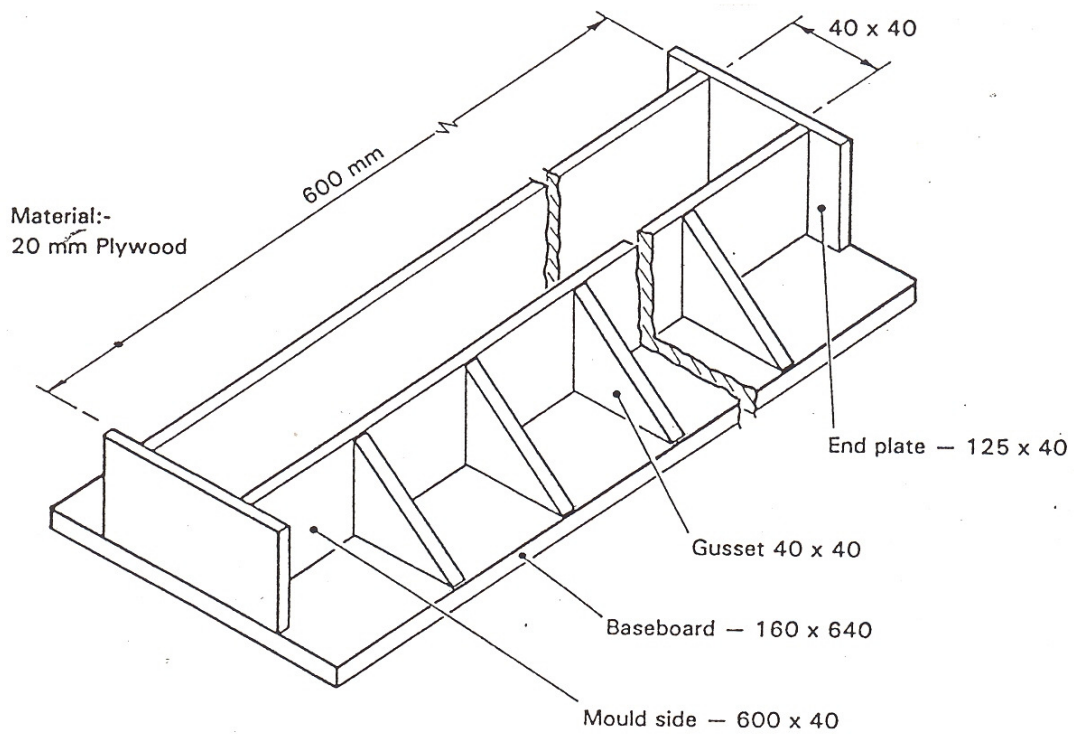

Shrinkage is very important when choosing a soil for building. If a soil shrinks a lot it will tend to cause cracks in a building. The more clay that is in a soil the more it tends to shrink.

When you have your mould box, or boxes, you will need to prepare the soil for the test. First put the soil through sieve (5 or 6 mm should do). Now mix this soil with water until it is near its "liquid limit". The way to test if the soil is at this limit is given below. You do not have to have the exact equipment but the closer you keep to this method the more reliable your results are.

FIG 4.8

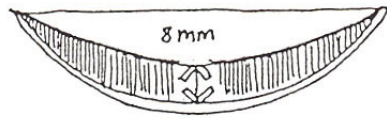

FIG 4.9

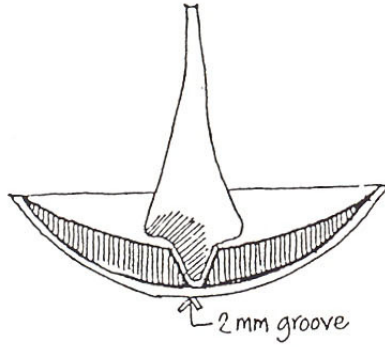
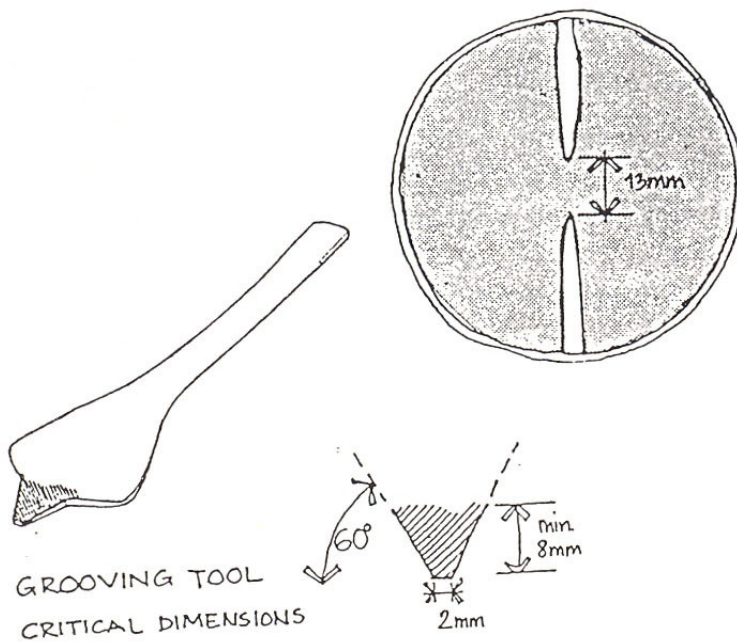
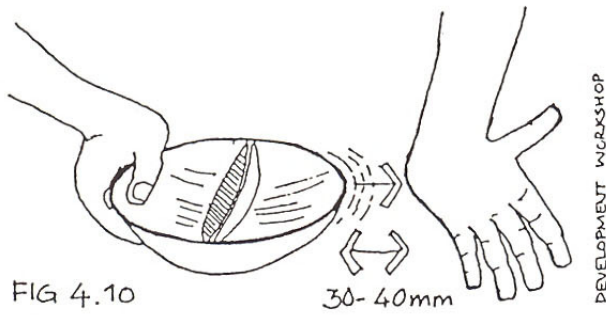
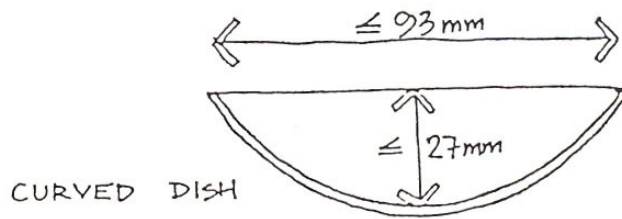

FIG 4.10





Method:

Mix 70gms of the sample with drinkable water to the consistency of a thick paste. Smooth the sample into the curved dish to a maximum depth of 10mm (Fig 4.8). Separate the mixture into two equal portions by drawings the grooving tool across the diameter of the dish. This should leave a V-shaped groove, with a gap at the bottom 2mm wide, and slopes to the groove at an angle of 60° from the horizontal (Fig 4.9). If you don't have a suitable grooving tool, carefully use a knife blade to make as accurate a groove as possible.

Hold the dish firmly in one hand with the groove in the soil pointing away from you. Then tap the dish slightly with a horizontal motion against the heel of the other hand 10 times. The dish should be moved a distance of about 30-40mm to strike against the other hand, which should remain still (fig 4.10). If it takes more than 10 taps to make the groove flow together, the soil is too dry: add a little water. If it flows together with less than 10 taps, it is too wet: add more dry soil. When the moisture content of the soil has been adjusted so that the two portions of soil come into contact at the bottom of the groove along a continuous distance of 13mm after 10 taps (Fig 4.11), the soil is at the liquid limit.

Once you think you have the mixture about right, grease the inside of your mould. Silicon grease is best, but a small amount of cooking oil or old engine oil will do. Now press the soil mixture into the mould box making sure there is no air left in the mixture and that the mould is completely full.

The mould is then left for the soil to dry. If drying is in the shade, this can take about 10 days. Drying in the sun will take about 5 days. It is a good idea to put two moulds containing the same soil, one in the sun and one in the shade to compare results.

HOW TO UNDERSTAND THE RESULTS: If the soil shrinks a lot and "hogs" up (see photo on following page), then there is a lot of clay in it. A soil that shrinks less and cracks across the width of the mould (photo) is high in sand and low in clay and silt.

If necessary, push the portions of soil in the mould back together and measure their total length. Subtract this length from the length of the mould to get the shrinkage.

If OPC is used as the stabilise, then the more clay that there is in the soil the more OPC will be needed. The table below shows how to know the amount of OPC needed from the shrinkage tests.

| Measured shrinkage | Cement to soil ratio |
|--------------------|--|
| Under 15mm | 1 part cement to 18 parts soil (5.56%) |
| 15 to 30mm | 1 part cement to 16 parts soil (6.25%) |
| 30 to 45mm | 1 part cement to 14 parts soil (7.14%) |
| 45 to 60mm | 1 part cement to 12 parts soil (8.33%) |

If the soil shrinks more than 60mm, or it is more than 30% clay, then lime or a combination of lime and OPC may be the best choice of stabiliser. The amount of lime needed increases as the clay content of the soil increases. The best way to find out how much lime is needed is to make blocks with different amounts of lime (everything else being the same) and have them tested for strength.

As a rough guide the table on page 10 can be used to get lime quantities for a first test.

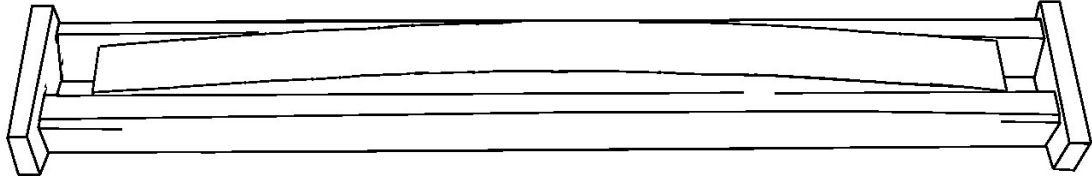

Linear shrinkage of a high silt/clay soil

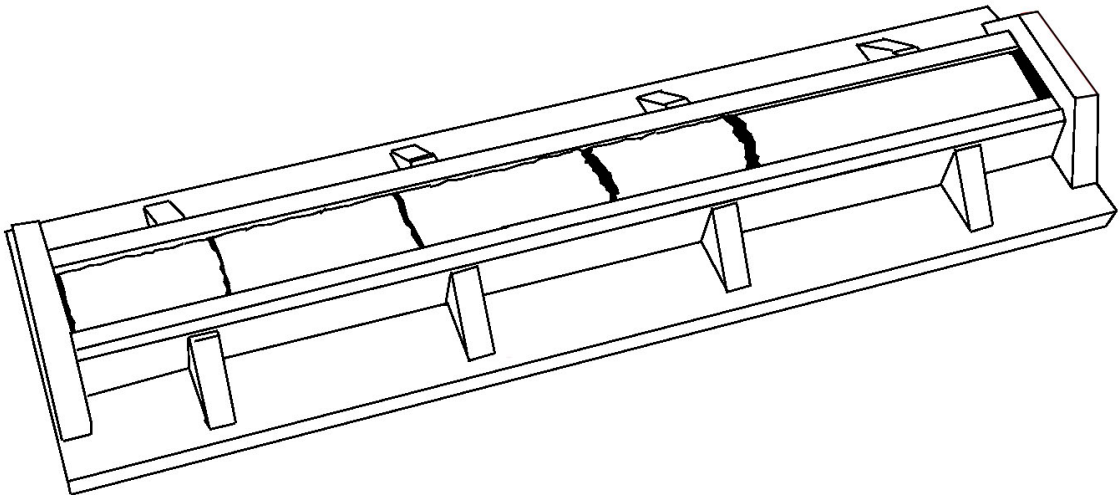

Linear shrinkage of a sandy soil

Percentage of clay in the soil

| | |
|----|----------------------------|
| 30 | 3 (approx 1:32), 5 and 7 |
| 40 | 4 (1:24), 6 and 7 |
| 50 | 5 (1:19), 7 and 9 |
| 60 | 6 (approx 1: 16), 8 and 10 |
| 70 | 7 (approx 1: 13) and 9 |
| 80 | 8 (1:11.5) and 10 |
| 90 | 10 (1:9) |

NOTE: All percentages and ratios are given by mass, which we can call weight. For example: 1 part cement to 16 parts soil, or 6.25%, means that a 50 kg bag of cement would be used

with 800 kgs of soil. However, dry cement and dry powdered soil have very similar "densities", so if it is easier to measure by volume (for example a bucket full or a wheelbarrow full) then your results should be okay. Make sure that you write down which measure you used in your tests - volume or weight.

DENSITY: A 50 kg bag of cement will fill a box that is 30 centimetres (cm) long, 30 cm wide and 30 cm deep. The volume of the box is $30 \times 30 \times 30 = 27,000$ cubic centimetres. The density of the cement is 50 kgs per 27,000 cubic centimetres. We usually make this number tidier so that we can compare the densities of different things;

$$50\text{kgs}/27,000\text{cm}^3 = 1 \text{ kg}/540\text{cm}^3 = 1852 \text{ kg/m}^3$$

Density is usually given in kg/m^3 . Examples of densities are: Mild Steel = $7,800\text{kg/m}^3$; Wood = $4,000$ to $8,000\text{kg/m}^3$; Ice = 920kg/m^3 .

Now you should have some idea of which stabiliser and how much to use with your soil. If you are making a lot of blocks, then you should have some tested for water absorption and wet strength when crushed. The Standard Association of Zimbabwe can carry out these tests. They will tell you how many blocks you need to take for testing (probably 10). However, if you are building a very simple structure or building outside city limits, then you can just take a few blocks to get an idea of their strength.

SOIL PREPARATION

We will deal more with testing blocks in section 5. Remember to keep good records of the soils that you test. When it comes to making sample blocks for testing you must have good records of which block has which stabiliser and how much.

When you dig your soil it may be wet or dry. Dry soil is easier to

prepare and work with. If your soil is wet leave it to dry out in the sun turning it sometimes. Dry soil should be crushed using tools like punners or hammer-hoes as in the picture below.

proportions for stabilising.

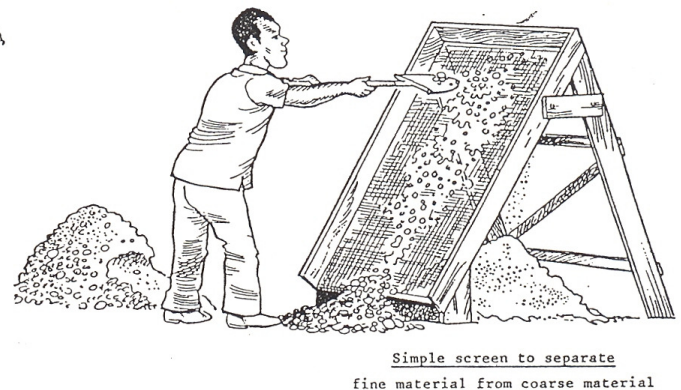
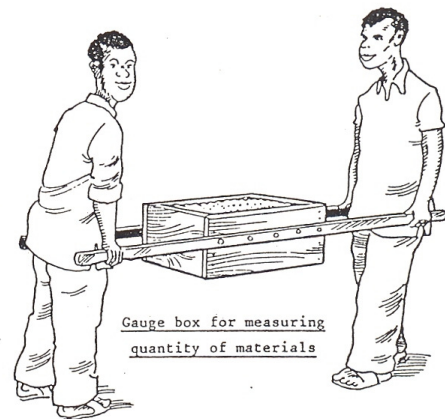
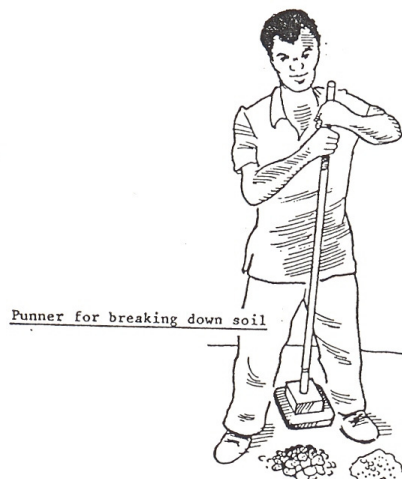

The soil is then passed through a sieve or screen. The sieve should have a mesh size of 5 or 6mm. All stones bigger than this should be put aside as they will cause cracking if they get into a block.

If your soil has too much clay, you might mix it with sand to get the right proportions for stabilising.

Once the soil is crushed and sieved it will need to be mixed with the stabiliser. Mixing should be done with the soil and the stabiliser both dry. It is probably easiest to measure quantities by volume (although weight would be more exact).

Perhaps, when you know exactly how much stabiliser to soil you need, you might make a gauge box as shown. A wheelbarrow or buckets will do just as well to measure volumes.

Mix the soil and stabiliser together very well. The best way to tell when you have done enough mixing is when the mix is all the same colour.

Mix in the amount of water that is needed slowly a little at a time. Sprinkle the water over the top of the mix with a watering can. Mix well, turning the mix over several times.

The mix is wet enough when a handful dropped from shoulder height just breaks up when it hits the ground (The Drop Test). You should not be able to squeeze water out of a handful of the mix.

If you are using cement the mixture should be pressed straight away. With lime the mix should be allowed to stand for a short time and then turned again before pressing.

Hand mixing with shovels is often the most efficient, satisfactory and cheap method. A concrete mixer is not suitable for mixing soil because the soil will stick badly inside the drum.

DROP TEST - no equipment required - medium accuracy.

Method:

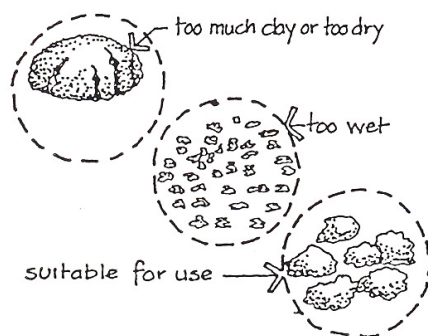

Take some soil that has had some water added to it. Squeeze the damp soil into a ball in your hand. Then with your arm straight out at shoulder level, drop the soil ball onto a smooth clean surface at ground level and observe the result:

if the soil stays in one piece it is too dry; add water and try again;

if the soil is still in one piece the clay content is too high;

if the soil breaks into many pieces, it is too wet; leave it to dry a while and try again;

when the dropped ball breaks into only a few pieces it is close to the optimum water content, and suitable for use.

Continue to use the drop test to check the water content of the soil as it is being used.

BLOCK PRESSING

It has already been mentioned the mixture to be pressed should not be too wet. You cannot press water and if you try your press machine will probably break. Another simple test is to take a small amount of your mixture and roll it between your hands until you have a roll about 6mm in diameter and 50mm long. Now, on a smooth surface, slowly roll it down to 3mm diameter. If the sample is too wet it rolls down to 3mm or less without breaking. If it is too dry it will break when it is still thicker than 3mm. The perfect sample will break into pieces longer than 10mm when the diameter is 3mm.

Normally you might start by adding 10% of water (by volume) slowly to your mix. So if you have a dry mix that is 20 buckets in volume, you will probably start by adding 2 buckets of water a little at a time. You should keep testing the mix as you wet it until it is right.

Experience is the best way to know if the mix is right. When you have made a lot of blocks you will know when the mix is right for pressing. But still do the tests from time to time to prove that you are right.

There are two types of manual presses that you could use. The first is called a "constant pressure press". This type of press will press any quantity of mix that is put into it. One or two people apply their strength to a lever until they cannot compress the block any more. One problem with this type of machine is that it can produce blocks of different thicknesses depending how much material is put into it. It is very important with this sort of machine to have a gauge box so that the same amount of mix goes into every block. In this way most blocks should be the same thickness.

For this first type, the volume of the compacted block compared to the empty press chamber should be about 1 to 1.65. So if the empty press chamber measures 32cm long x 16cm wide x 14cm deep (volume = 7,168 cubic cm) then the pressed block should measure 32cm x 16cm x 8.5cm (volume = 4,352 cm). As a very rough guide, the finished block should have a height slightly more than 3/5 of the empty chamber height.

The second type of machine is called a "constant volume" press. This type has a definite "stop" when no more pressing can be done. As long as this stop is reached, the blocks produced will be all the same thickness. If the stop point is not reached, there is too much mixture in the press and the block that comes out will be too thick. Blocks like this should be broken up and put back into the mix. With this type of machine you still need to make sure that the same amount of mix goes into every block by using a gauge box, or by filling the chamber exactly the same each time. The strength of a block comes from the amount it has been pressed. If there is too little mix in the press, the block that comes out will be less dense and so less strong than it should be.

BLOCK CURING

From the press the blocks can be carried by hand to the "curing" area. It is best to use two flat boards to lift and carry the block between. It is easier to lift blocks in this way and it helps prevent damage to the block.

Curing is the process of the block getting stronger and setting hard. SSB's need to be cured in the shade on a clean and flat area. If no building is available shade can be provided by cut thatch grass in a thick layer over the blocks.

The blocks can be stacked together after 24 hours, still in the shade. They should not be stacked tightly together or too high or the bottom layers will start to crack. Perhaps blocks should be stacked no more than 5 high until they are fully cured. Spaces should be left for air to pass between the stacked blocks.

Blocks stabilised with cement should be kept moist for 4 or 5 days. Lime stabilised blocks are kept moist for up to 1 week. One good way to do this is to sprinkle water on the top layer of blocks once each day and cover the stack with plastic sheeting. If blocks are not kept damp, the clay in the soil will shrink too fast and the blocks will crack and be weak.

When blocks have been kept moist for the right number of days they can be stacked tightly together. It is still a good idea to keep the blocks in shade, perhaps under a thick layer of thatch grass if covered building space is short.

The blocks are still not fully cured. They are still setting and growing stronger. Blocks stabilised with OPC should not be sold or used for at least 28 days after they are made. At this time the block should have about 75 % (3/4) of its final strength. The blocks should keep growing stronger for more than a year!

Lime stabilised blocks grow stronger more slowly. They should not be sold for at least 37 days. Lime blocks will probably have 75% of their final strength after this time and will also keep growing stronger.

Good curing is very important. Blocks that are not cured properly will tend to crack and be weak. It is a good idea to leave a few blocks to dry in the sun and not wet them. These sun dried blocks will probably crack badly and perhaps not harden at all. If these blocks are tested with others from the same day that have been cured properly there should be a big difference in their strength.

BLOCK TESTING

Cured blocks can be sent to the Standards Association of Zimbabwe (SAZ) or some commercial companies for testing. The tests that can be carried are: Dry compressive strength; Water absorption and wet compressive strength. The Model Building By-Laws (available from SAZ) give standards for SSBs. In a sample of 10 concrete blocks the minimum average compressive strength must be 2.8

MPa (compare this to a common fired clay brick which will have a compressive strength around 7 MPa). In a sample of 10 blocks, no single block should be weaker than 2.2 MPa. Increase in mass after 24 hours should not exceed 12% of dry mass. Linear expansion after immersion in water after 24 hours should not exceed .05% for structural walls and .1 % for internal walls.

It is expensive to send blocks for testing to government laboratories or commercial companies. If you are making blocks in an area where there is not a restriction on what can be used, there are some tests that you can do yourself. These tests should be done to make sure that building made with the blocks are safe and will not fall down, especially when the blocks get wet.

- (a) All your blocks should be the same sizes. If your block should be 295mm long x 140mm wide x 88mm high, then the measured length should always be between 292 and 295mm, the width between 138 and 141 mm and the height between 87 and 90mm.
- (b) The density of a wet block should be at least 1,870 kg/cubic metre and it would be better at 2,200 kg/ cubic metre.

If your block measures the same as the example in (a) above then its volume is 29.5cm x 14.0cm x 8.8cm = 3,634 cubic cm. So its weight should be at least 1,870 x (3634/1,000,000) = 6.80 kg.

- (c) For a dry block (after at least 28 days for OPC) the density should be at least 1,700 kg/cubic metre and it would be better at 2,000 kg/cubic metre.

So a dry block of the size used in our example should weigh at least 6.19 kg.

- (d) One important test is to see how the blocks stand up to getting wet and drying out again as they would in use in a building. Take 5 fully cured blocks and put them in water so they are completely covered. Leave them in the water for at least 12 hours overnight. Take them out and let them dry in the sun for the day. Repeat this process every day for 7 days.

If the blocks fall apart, crack or bits flake off there is something wrong. It might be that the mix is wrong or the soil is bad for SSB's.

- (e) When the wetting and drying test is being done you can also do the test for water absorption. Weigh the 5 blocks before they are put in water (remember to mark each block with a number that will not wash off). Weigh the blocks again after they have soaked overnight.

A good block will not absorb more than 12 % water by weight. So if the dry block weighs 6.2 kg and the wet block weighs 8.13 kg what is the percentage of water absorbed. The calculation to find out the percentage water absorption is given below:

$$\text{PERCENTAGE WATER} = ((\text{WET WEIGHT} - \text{DRY WEIGHT})/\text{DRY WEIGHT}) \times 100$$

Example: $((8.13-6.2)/6.2) \times 100 = 31\%$

This would be a bad block to use.

- (f) Compressive strength testing can be done on the site but a machine like the ones below will have to be made.

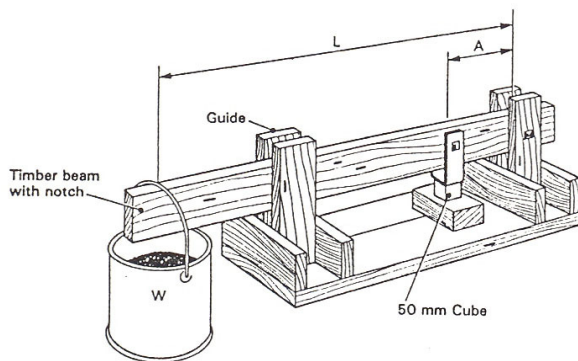

Timber beam : 100 x 50 x 1,800 mm length
 A = 85 mm
 L = 1,676 mm
 W = Weight of hanger and contents

When the very large weights required to do compression tests on full size blocks are not available, it is common to make small test samples, 50mm in diameter or square, and 50mm high. If these cannot be made on site, use a saw or mason's axe to cut a larger sample or block into roughly the right size and measure its surface area.

Practical equipment for compression testing using a lever system is shown on the left. Cover the sample with plywood or a board 20mm thick (more for larger samples). Place weights on the end of the lever arm, or suspend them from it.

Calculate the compression (C) as follows:

$$C = W \times O (O + A)$$

where -

W = weight;

D = distance from weight to point of resistance (variable);

A = distance from point of resistance to centre of the sample (300mm).

Compression is increased by increasing either W, or O, or both, until the sample fails. Divide the compression by the surface area of the sample for the result. Test five samples for an average compressive strength.

Example: Say your sample is a cube of 5cm (0.05m) sides. So its surface area $S = 5 \times 5 = 25$ square centimetres.

Now if the distance A on the machine is 85mm, the distance L is 1,676mm and the weight (W) used is 50kgs when the cube starts to crush when then the compression C is given by:

$$C = 50 \times (1,676/85) = 986\text{kgs}$$

$$\begin{aligned}\text{So the compressive strength} &= ((986/(0.05 \times 0.05)) \\ &= 394,400 \text{ kgs/square metre}\end{aligned}$$

To compare this to the strengths for blocks given in MPa (Mega Pascals, 1 Mpa = 1 Mega Newton/square metre). Mega means 1,000,000. 1 kg is equal to approximately 10 Newtons, so:

394,400 kgs/square metre

$$\begin{aligned}&= 3,944,000 \text{ Newton/square metre} \\ &= 3.944 \text{ Mega Newton/square metre} \\ &= 3.944 \text{ MPa}\end{aligned}$$

So this sample is strong enough.

- (g) A very simple test is the "ring" test. If two fully cured blocks are knocked together a good sharp ringing noise should be heard. If the blocks ring they are probably strong and water resistant. If they sound hollow or "dull" they are probably not very good.
- (h) Another simple test is to try and scratch with your thumbnail a fully cured block that has been soaked overnight. If you cannot make a mark the block is probably okay, at least for single storey buildings.

CONCLUSION

The most important things that affect the quality of SSB's are how hard it has been pressed, the choice and amount of stabiliser used, soil preparation and block curing. All these things are in the hands of the blockmaker to control except the compaction pressure which depends on the machine used.

There are at least two presses made in Zimbabwe:

- 1 A constant volume machine - APTECH, PO Box AY 175, Amby, Harare.
- 2 A constant pressure machine - Ecological Designs, Box 6084, Harare.

Prepared by the Building Materials Programme, ITDG, PO Box 1744, Harare. Telephone 796420 or 796409.